

SECTION **HA**

HEATER & AIR CONDITIONING SYSTEM

A
B
C
D
E
F
G
H
HA
J
K
L
M
N
O
P

CONTENTS

PRECAUTION	3	PERIODIC MAINTENANCE	23
PRECAUTIONS	3	REFRIGERANT	23
Precaution for Supplemental Restraint System (SRS) "AIR BAG" and "SEAT BELT PRE-TENSIONER"	3	Description	23
Precaution for Work	3	Leak Test	23
Precaution for Procedure without Cowl Top Cover.....	4	Recycle Refrigerant	25
Precaution for Working with HFC-134a (R-134a).....	4	Charge Refrigerant	25
Contaminated Refrigerant	4	OIL	27
Precaution for Leak Detection Dye	4	Description	27
Precaution for Refrigerant Connection	5	Inspection	27
Precaution for Service Equipment	7	Perform Oil Return Operation	27
PREPARATION	10	Oil Adjusting Procedure for Components Replacement Except Compressor	27
PREPARATION	10	Oil Adjusting Procedure for Compressor Replacement	28
Special Service Tool	10	REFRIGERATION SYSTEM	30
HFC-134a (R-134a) Service Tool and Equipment... ..	10	Inspection	30
Commercial Service Tool	11	Performance Chart	30
Sealant and/or Oil	12	PERFORMANCE TEST	32
SYSTEM DESCRIPTION	13	Inspection	32
REFRIGERATION SYSTEM	13	REMOVAL AND INSTALLATION	34
Refrigerant Cycle	13	COMPRESSOR	34
Component Part Location	14	Exploded View	34
Refrigerant System Protection	14	Removal and Installation	34
BASIC INSPECTION	16	Removal and Installation	35
DIAGNOSIS AND REPAIR WORK FLOW	16	COOLER PIPE AND HOSE	36
Work Flow	16	Exploded View	36
SYMPTOM DIAGNOSIS	18	LOW-PRESSURE FLEXIBLE HOSE	36
REFRIGERATION SYSTEM SYMPTOMS	18	LOW-PRESSURE FLEXIBLE HOSE : Removal and Installation	36
Trouble Diagnoses for Abnormal Pressure	18	LOW-PRESSURE PIPE	37
Symptom Matrix Chart	20	LOW-PRESSURE PIPE : Removal and Installation	37
NOISE	22	HIGH-PRESSURE FLEXIBLE HOSE	38
Symptom Table	22		

HIGH-PRESSURE FLEXIBLE HOSE : Removal and Installation	38	Exploded View	44
HIGH-PRESSURE PIPE	38	HEATER & COOLING UNIT ASSEMBLY	44
HIGH-PRESSURE PIPE : Removal and Installation	38	HEATER & COOLING UNIT ASSEMBLY : Removal and Installation	45
CONDENSER	41	HEATER CORE	45
CONDENSER	41	HEATER CORE : Removal and Installation	46
CONDENSER : Exploded View	41	EVAPORATOR	46
CONDENSER : Removal and Installation	41	EVAPORATOR : Removal and Installation	46
CONDENSER PIPE ASSEMBLY	42	EXPANSION VALVE	46
CONDENSER PIPE ASSEMBLY : Removal and Installation	42	EXPANSION VALVE : Removal and Installation for Expansion Valve	46
LIQUID TANK	42	SERVICE DATA AND SPECIFICATIONS (SDS)	47
LIQUID TANK : Removal and Installation	42	SERVICE DATA AND SPECIFICATIONS (SDS)	47
REFRIGERANT PRESSURE SENSOR	43	Compressor	47
REFRIGERANT PRESSURE SENSOR : Removal and Installation	43	Oil	47
HEATER & COOLING UNIT ASSEMBLY	44	Refrigerant	47

PRECAUTIONS

< PRECAUTION >

PRECAUTION

PRECAUTIONS

Precaution for Supplemental Restraint System (SRS) "AIR BAG" and "SEAT BELT PRE-TENSIONER"

INFOID:000000012284058

The Supplemental Restraint System such as "AIR BAG" and "SEAT BELT PRE-TENSIONER", used along with a front seat belt, helps to reduce the risk or severity of injury to the driver and front passenger for certain types of collision. Information necessary to service the system safely is included in the SR and SB section of this Service Manual.

WARNING:

- To avoid rendering the SRS inoperative, which could increase the risk of personal injury or death in the event of a collision which would result in air bag inflation, all maintenance must be performed by an authorized NISSAN/INFINITI dealer.
- Improper maintenance, including incorrect removal and installation of the SRS, can lead to personal injury caused by unintentional activation of the system. For removal of Spiral Cable and Air Bag Module, see the SR section.
- Do not use electrical test equipment on any circuit related to the SRS unless instructed to in this Service Manual. SRS wiring harnesses can be identified by yellow and/or orange harnesses or harness connectors.

PRECAUTIONS WHEN USING POWER TOOLS (AIR OR ELECTRIC) AND HAMMERS

WARNING:

- When working near the Airbag Diagnosis Sensor Unit or other Airbag System sensors with the Ignition ON or engine running, DO NOT use air or electric power tools or strike near the sensor(s) with a hammer. Heavy vibration could activate the sensor(s) and deploy the air bag(s), possibly causing serious injury.
- When using air or electric power tools or hammers, always switch the Ignition OFF, disconnect the battery and wait at least three minutes before performing any service.

Precaution for Work

INFOID:000000012284064

- When removing or disassembling each component, be careful not to damage or deform it. If a component may be subject to interference, be sure to protect it with a shop cloth.
- When removing (disengaging) components with a screwdriver or similar tool, be sure to wrap the component with a shop cloth or vinyl tape to protect it.
- Protect the removed parts with a shop cloth and prevent them from being dropped.
- Replace a deformed or damaged clip.
- If a part is specified as a non-reusable part, always replace it with a new one.
- Be sure to tighten bolts and nuts securely to the specified torque.
- After installation is complete, be sure to check that each part works properly.
- Follow the steps below to clean components:
 - Water soluble dirt:
 - Dip a soft cloth into lukewarm water, wring the water out of the cloth and wipe the dirty area.
 - Then rub with a soft, dry cloth.
 - Oily dirt:
 - Dip a soft cloth into lukewarm water with mild detergent (concentration: within 2 to 3%) and wipe the dirty area.
 - Then dip a cloth into fresh water, wring the water out of the cloth and wipe the detergent off.
 - Then rub with a soft, dry cloth.
 - Do not use organic solvent such as thinner, benzene, alcohol or gasoline.
 - For genuine leather seats, use a genuine leather seat cleaner.

PRECAUTIONS

< PRECAUTION >

Precaution for Procedure without Cowl Top Cover

INFOID:000000012471706

When performing the procedure after removing cowl top cover, cover the lower end of windshield with urethane, etc., to prevent damage to windshield.

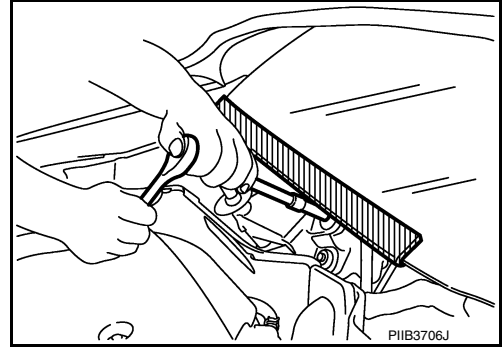

Precaution for Working with HFC-134a (R-134a)

INFOID:000000012284059

WARNING:

- CFC-12 (R-12) refrigerant and HFC-134a (R-134a) refrigerant are not compatible. If the refrigerants are mixed compressor failure is likely to occur. Refer to [HA-23, "Leak Test"](#). To determine the purity of HFC-134a (R-134a) in the vehicle and recovery tank, use Refrigerant Recovery/Recycling Recharging equipment and Refrigerant Identifier.
- Use only specified oil for the HFC-134a (R-134a) A/C system and HFC-134a (R-134a) components. If oil other than that specified is used, compressor failure is likely to occur.
- The specified HFC-134a (R-134a) oil rapidly absorbs moisture from the atmosphere. The following handling precautions must be observed:
 - When removing refrigerant components from a vehicle, immediately cap (seal) the component to minimize the entry of moisture from the atmosphere.
 - When installing refrigerant components to a vehicle, do not remove the caps (unseal) until just before connecting the components. Connect all refrigerant loop components as quickly as possible to minimize the entry of moisture into system.
 - Only use the specified oil from a sealed container. Immediately reseal containers of oil. Without proper sealing, oil will become moisture saturated and should not be used.
 - Avoid breathing A/C refrigerant and oil vapor or mist. Exposure may irritate eyes, nose and throat. Remove HFC-134a (R-134a) from the A/C system using certified service equipment meeting requirements of SAE J2210 [HFC-134a (R-134a) recycling equipment], or J2209 [HFC-134a (R-134a) recycling equipment]. If accidental system discharge occurs, ventilate work area before resuming service. Additional health and safety information may be obtained from refrigerant and oil manufacturers.
 - Do not allow A/C oil to come in contact with styrofoam parts. Damage may result.

Contaminated Refrigerant

INFOID:000000012284060

If a refrigerant other than pure HFC-134a (R-134a) is identified in a vehicle, your options are:

- Explain to the customer that environmental regulations prohibit the release of contaminated refrigerant into the atmosphere.
- Explain that recovery of the contaminated refrigerant could damage your service equipment and refrigerant supply.
- Suggest the customer return the vehicle to the location of previous service where the contamination may have occurred.
- If you choose to perform the repair, recover the refrigerant using only **dedicated equipment and containers. Do not recover contaminated refrigerant into your existing service equipment.** If your facility does not have dedicated recovery equipment, you may contact a local refrigerant product retailer for available service. This refrigerant must be disposed of in accordance with all federal and local regulations. In addition, replacement of all refrigerant system components on the vehicle is recommended.
- If the vehicle is within the warranty period, the air conditioner warranty is void. Please contact NISSAN Customer Affairs for further assistance.

Precaution for Leak Detection Dye

INFOID:000000012284061

- The A/C system contains a fluorescent leak detection dye used for locating refrigerant leaks. An ultraviolet (UV) lamp is required to illuminate the dye when inspecting for leaks.

PRECAUTIONS

< PRECAUTION >

- Always wear fluorescence enhancing UV safety goggles to protect your eyes and enhance the visibility of the fluorescent dye.
- A compressor shaft seal should not be repaired because of dye seepage. The compressor shaft seal should only be repaired after confirming the leak with an electronic refrigerant leak detector (J-41995).
- Always remove any dye from the leak area after repairs are complete to avoid a misdiagnosis during a future service.
- Do not allow dye to come into contact with painted body panels or interior components. If dye is spilled, clean immediately with the approved dye cleaner. Fluorescent dye left on a surface for an extended period of time **cannot be removed**.
- Do not spray the fluorescent dye cleaning agent on hot surfaces (engine exhaust manifold, etc.).
- Do not use more than one refrigerant dye bottle (1/4 ounce / 7.4 cc) per A/C system.
- Leak detection dyes for HFC-134a (R-134a) and HC-12 (R-12) A/C systems are different. Do not use HFC-134a (R-134a) leak detection dye in R-12 A/C systems or HC-12 (R-12) leak detection dye in HFC-134a (R-134a) A/C systems or A/C system damage may result.
- The fluorescent properties of the dye will remain for over three (3) years unless a compressor failure occurs.

Precaution for Refrigerant Connection

INFOID:000000012284062

A new type refrigerant connection has been introduced to all refrigerant lines except the following locations.

- Expansion valve to cooling unit
- Evaporator pipes to evaporator (inside cooling unit)
- Refrigerant pressure sensor

FEATURES OF NEW TYPE REFRIGERANT CONNECTION

- The O-ring has been relocated. It has also been provided with a groove for proper installation. This eliminates the chance of the O-ring being caught in, or damaged by, the mating part. The sealing direction of the O-ring is now set vertically in relation to the contacting surface of the mating part to improve sealing characteristics.
- The reaction force of the O-ring will not occur in the direction that causes the joint to pull out, thereby facilitating piping connections.

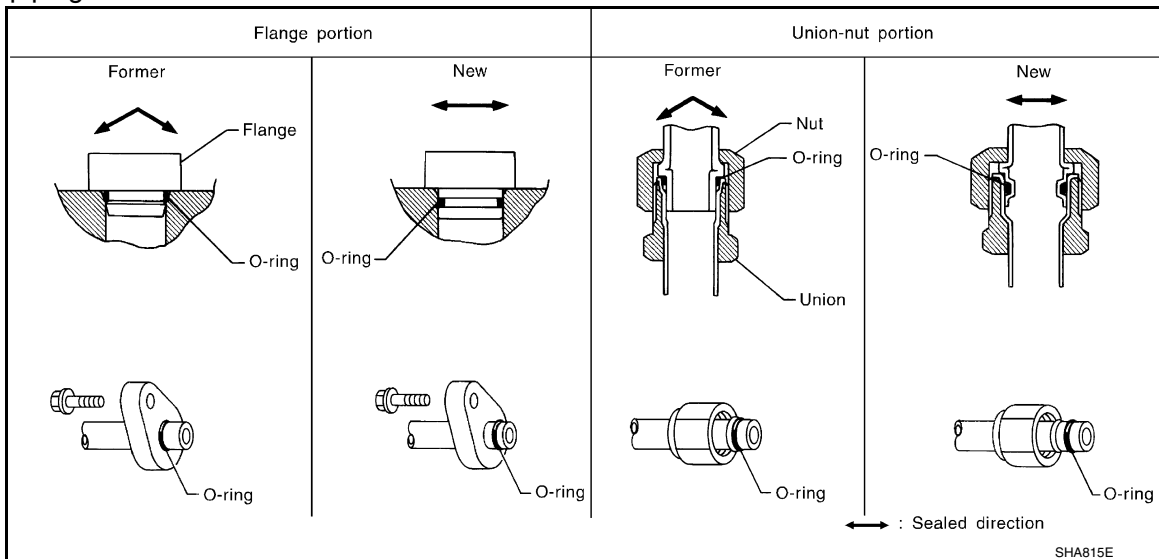

O-RING AND REFRIGERANT CONNECTION

PRECAUTIONS

< PRECAUTION >

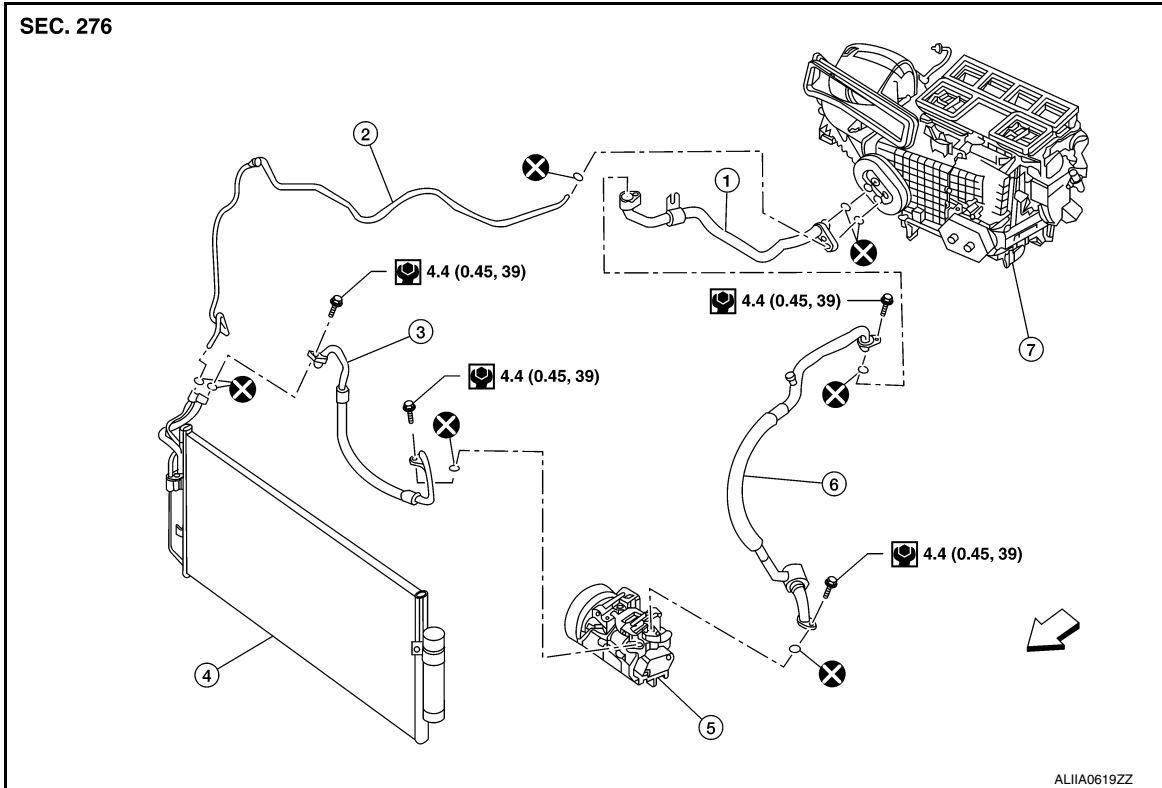

- | | | |
|--------------------------------------|-----------------------|--------------------------------|
| 1. Low-pressure pipe | 2. High-pressure pipe | 3. High-pressure flexible hose |
| 4. Condenser assembly | 5. Compressor | 6. Low-pressure flexible hose |
| 7. Heating and cooling unit assembly | ↔ Front | |

CAUTION:

The new and former refrigerant connections use different O-ring configurations. Do not confuse O-rings since they are not interchangeable. If a wrong O-ring is installed, refrigerant will leak at, or around, the connection.

O-Ring Specifications*

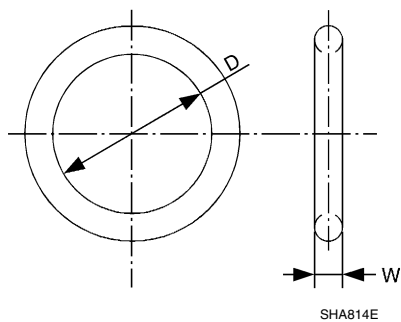

Connection type	O-ring size	D mm (in)	W mm (in)
New	8	6.8 (0.268)	1.85 (0.0728)
Former	10	9.25 (0.3642)	1.78 (0.0701)
New	12	10.9 (0.429)	2.43 (0.0957)
Former		11.0 (0.433)	2.4 (0.094)
New	16	13.6 (0.535)	2.43 (0.0957)
Former		14.3 (0.563)	2.3 (0.091)
New	19	16.5 (0.650)	2.43 (0.0957)
Former		17.12 (0.6740)	1.78 (0.0701)
New	24	21.8 (0.858)	2.4 (0.094)

*: Always check with the Parts Department for the latest parts information.

WARNING:

Make sure all refrigerant is discharged into the recycling equipment and the pressure in the system is less than atmospheric pressure. Then gradually loosen the discharge side hose fitting and remove it.

CAUTION:

When replacing or cleaning refrigerant cycle components, observe the following.

- When the compressor is removed, store it in the same position as it is when mounted on the car. Failure to do so will cause oil to enter the low pressure chamber.
- When connecting tubes, always use a torque wrench and a back-up wrench.

PRECAUTIONS

< PRECAUTION >

- After disconnecting tubes, immediately plug all openings to prevent entry of dirt and moisture.
- When installing an air conditioner in the vehicle, connect the pipes as the final stage of the operation. Do not remove the seal caps of pipes and other components until just before required for connection.
- Allow components stored in cool areas to warm to working area temperature before removing seal caps. This prevents condensation from forming inside A/C components.
- Thoroughly remove moisture from the refrigeration system before charging the refrigerant.
- Do not reuse the O-rings.
- Apply A/C compressor oil to the new O-rings for installation.
Oil name: ND-OIL8 (DENSO)
- O-ring must be closely attached to dented portion of tube.
- When replacing the O-ring, be careful not to damage O-ring and tube.
- Connect tube until you hear it click, then tighten the nut or bolt by hand until snug. Make sure that the O-ring is installed to tube correctly.
- After connecting line, conduct leak test and make sure that there are no leaks from connections. When the gas leaking point is found, disconnect that line and replace the O-ring. Then tighten connections of seal seat to the specified torque.

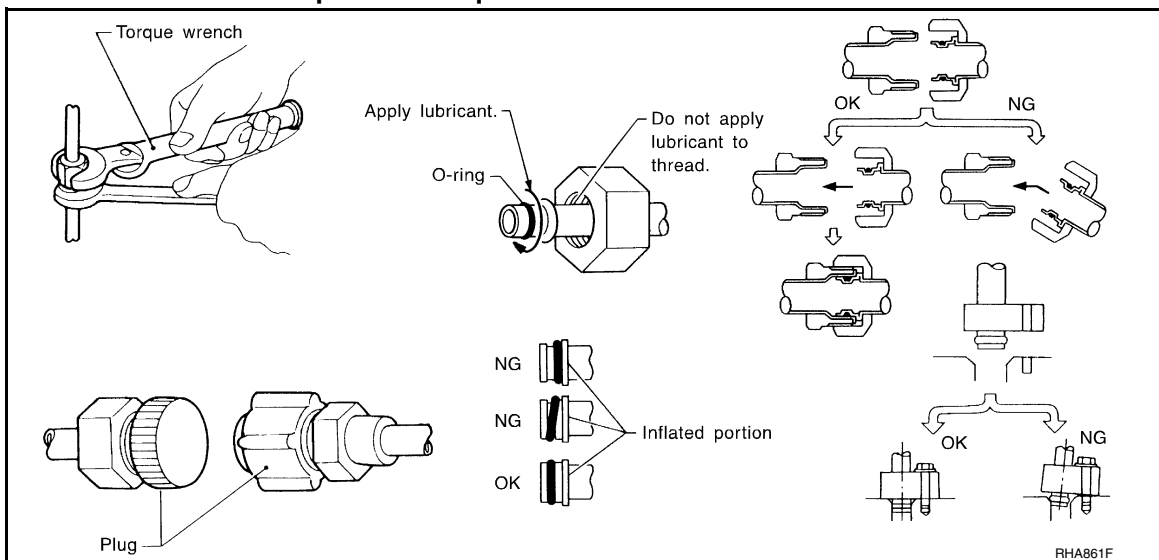

Precaution for Service Equipment

INFOID:000000012284063

RECOVERY/RECYCLING EQUIPMENT

Follow the manufacturer's instructions for machine operation and machine maintenance. Do not introduce any refrigerant other than that specified into the machine.

ELECTRONIC LEAK DETECTOR

Follow the manufacturer's instructions for tester operation and tester maintenance.

VACUUM PUMP

PRECAUTIONS

< PRECAUTION >

The oil contained inside the vacuum pump is not compatible with the specified oil for HFC-134a (R-134a) A/C systems. The vent side of the vacuum pump is exposed to atmospheric pressure so the vacuum pump oil may migrate out of the pump into the service hose. This is possible when the pump is switched off after evacuation (vacuuming) and hose is connected to it.

To prevent this migration, use a manual valve situated near the hose-to-pump connection, as follows.

- Usually vacuum pumps have a manual isolator valve as part of the pump. Close this valve to isolate the service hose from the pump.
- For pumps without an isolator, use a hose equipped with a manual shut-off valve near the pump end. Close the valve to isolate the hose from the pump.
- If the hose has an automatic shut off valve, disconnect the hose from the pump: as long as the hose is connected, the valve is open and oil may migrate.

Some one-way valves open when vacuum is applied and close under a no vacuum condition. Such valves may restrict the pump's ability to pull a deep vacuum and are not recommended.

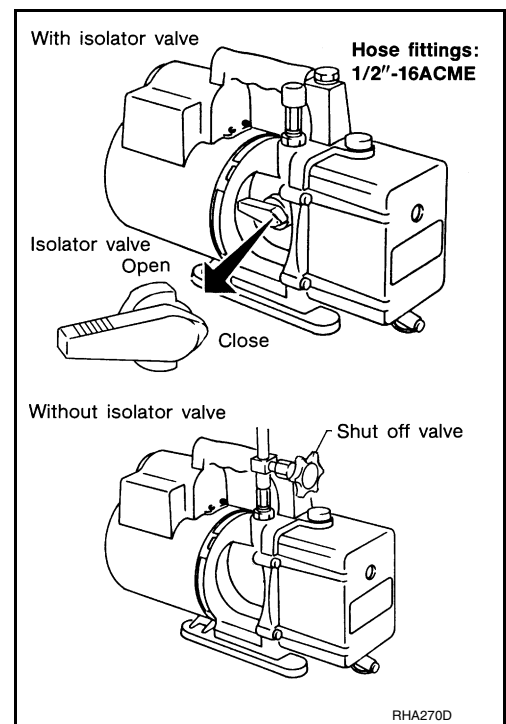

MANIFOLD GAUGE SET

Be certain that the gauge face indicates R-134a or 134a. Make sure the gauge set has 1/2"-16 ACME threaded connections for service hoses. Confirm the set has been used only with refrigerant HFC-134a (R-134a) along with specified oil.

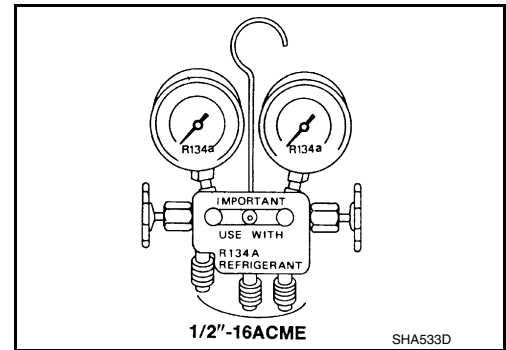

SERVICE HOSES

Be certain that the service hoses display the markings described (colored hose with black stripe). All hoses must include positive shut-off devices (either manual or automatic) near the end of the hoses opposite the manifold gauge.

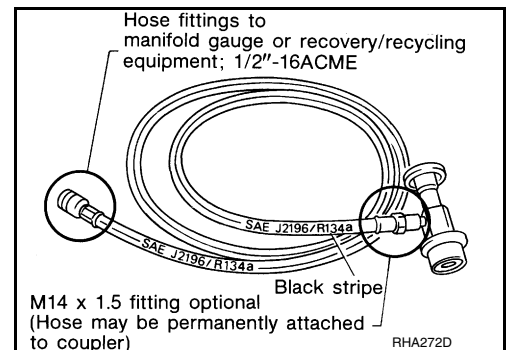

SERVICE COUPLERS

PRECAUTIONS

< PRECAUTION >

Do not attempt to connect HFC-134a (R-134a) service couplers to a CFC-12 (R-12) A/C system. The HFC-134a (R-134a) couplers will not properly connect to the CFC-12 (R-12) system. However, if an improper connection is attempted, discharging and contamination may occur.

Shut-off valve rotation	A/C service valve
Clockwise	Open
Counterclockwise	Close

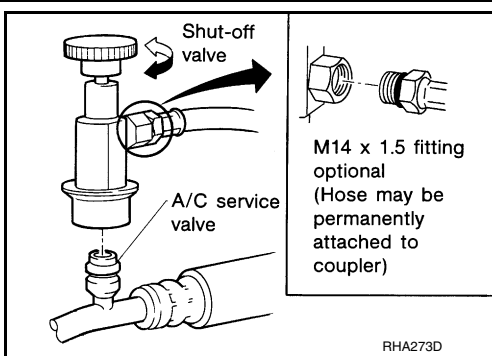

REFRIGERANT WEIGHT SCALE

Verify that no refrigerant other than HFC134a (R-134a) and specified oils have been used with the scale. If the scale controls refrigerant flow electronically, the hose fitting must be 1/2"-16 ACME.

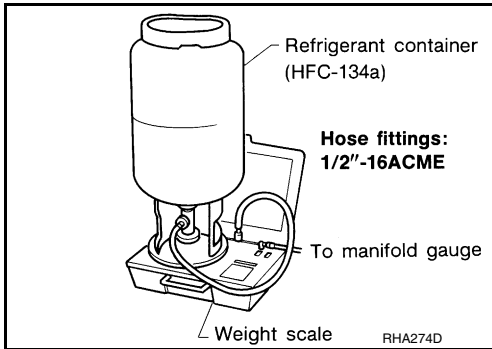

CHARGING CYLINDER

Using a charging cylinder is not recommended. Refrigerant may be vented into air from cylinder's top valve when filling the cylinder with refrigerant. Also, the accuracy of the cylinder is generally less than that of an electronic scale or of quality recycle/recharge equipment.

A
B
C
D
E
F
G
H
HA
J
K
L
M
N
O
P

PREPARATION

< PREPARATION >

PREPARATION

PREPARATION

Special Service Tool

INFOID:000000011933658

The actual shape of the tools may differ from those illustrated here.

Tool number (TechMate No.) Tool name	Description
(J-41425-NIS) Aluminum tube repair kit	Repairing leaks in A/C tubes
(J-38873-A) Drive plate installer	Installing pulley
(J-46534) Trim Tool Set	Removing trim components
(J-48710) Nissan ACR2009 RRR Unit	Refrigerant recovery, recycling and re-charging
(TIFZX) Electronic Refrigerant Leak Detector	Detects refrigerant leaks

HFC-134a (R-134a) Service Tool and Equipment

INFOID:000000011933659

Do not mix HFC-134a (R-134a) refrigerant and/or its specified oil with CFC-12 (R-12) refrigerant and/or its oil. Separate and non-interchangeable service equipment must be used for handling each type of refrigerant/oil. Refrigerant container fittings, service hose fittings and service equipment fittings (equipment which handles refrigerant and/or oil) are different between CFC-12 (R-12) and HFC-134a (R-134a). This is to avoid mixed use of the refrigerants/oil.

Adapters that convert one size fitting to another must not be used refrigerant/oil contamination will occur and compressor failure will result.

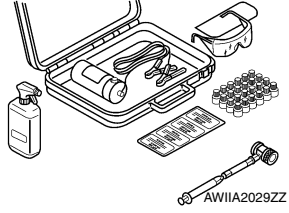

PREPARATION

< PREPARATION >

Tool number (TechMate No.) Tool name	Description	A
(J-43926) Refrigerant dye leak detection kit <div style="text-align: center;">  <p>AWIIA2029ZZ</p> </div>	Power supply: • DC 12V (battery terminal)	B
		C
		D

Commercial Service Tool

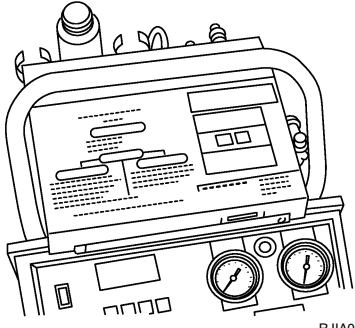
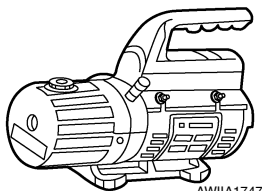
INFOID:000000011933660

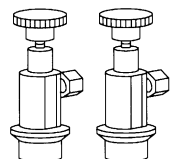
(TechMate No.) Tool name	Description	E
(J-41810-NI) Refrigerant identifier equipment (R-134a) <div style="text-align: center;">  <p>RJIA0197E</p> </div>	For checking refrigerant purity and system contamination	F
		G
		H
		HA
(J-39599) Vacuum Pump <div style="text-align: center;">  <p>AWIIA1747ZZ</p> </div>	Evacuate air from A/C system	J
		K
Power tool <div style="text-align: center;">  <p>PIIB1407E</p> </div>	Loosening nuts, screws and bolts	L
		M
		N
Service Couplers <ul style="list-style-type: none"> • High side coupler (J-39500-20A) • Low side coupler (J-39500-24A) <div style="text-align: center;">  <p>S-NT202</p> </div>	Hose fitting to service hose: • M14 x 1.5 fitting is optional or permanently attached	O
		P

PREPARATION

< PREPARATION >

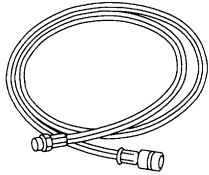
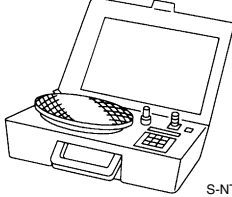
(TechMate No.) Tool name	Description
Service Hoses: <ul style="list-style-type: none"> • Low side hose (J-39500-72B) • High side hose (J-39500-72R) • Utility hose (J-39500-72Y) <div style="text-align: center;">  <p>S-NT201</p> </div>	Hose color: <ul style="list-style-type: none"> • Low side hose: Blue with black stripe • High side hose: Red with black stripe • Utility hose: Yellow with black stripe or green with black stripe Hose fitting to gauge: <ul style="list-style-type: none"> • 1/2"-16 ACME
(J-39699) Refrigerant weight scale <div style="text-align: center;">  <p>S-NT200</p> </div>	For measuring of refrigerant Fitting size-Thread size <ul style="list-style-type: none"> • 1/2"-16 ACME

Sealant and/or Oil

INFOID:0000000012366886

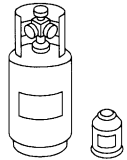
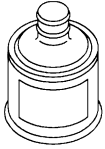
Tool number (TechMate No.) Tool name	Description
(—) HFC-134a (R-134a) Refrigerant <div style="text-align: center;">  <p>S-NT196</p> </div>	Container color: Light blue Container marking: HFC-134a (R-134a) Fitting size: Thread size <ul style="list-style-type: none"> • large container 1/2"-16 ACME
(—) ND-OIL8 (DENSO) <div style="text-align: center;">  <p>JMIIA1759ZZ</p> </div>	Type:ND-OIL8 (DENSO) Application: HFC-134a (R-134a) vane rotary compressors (NISSAN only)

REFRIGERATION SYSTEM

< SYSTEM DESCRIPTION >

SYSTEM DESCRIPTION

REFRIGERATION SYSTEM

Refrigerant Cycle

INFOID:000000012288534

Refrigerant flow

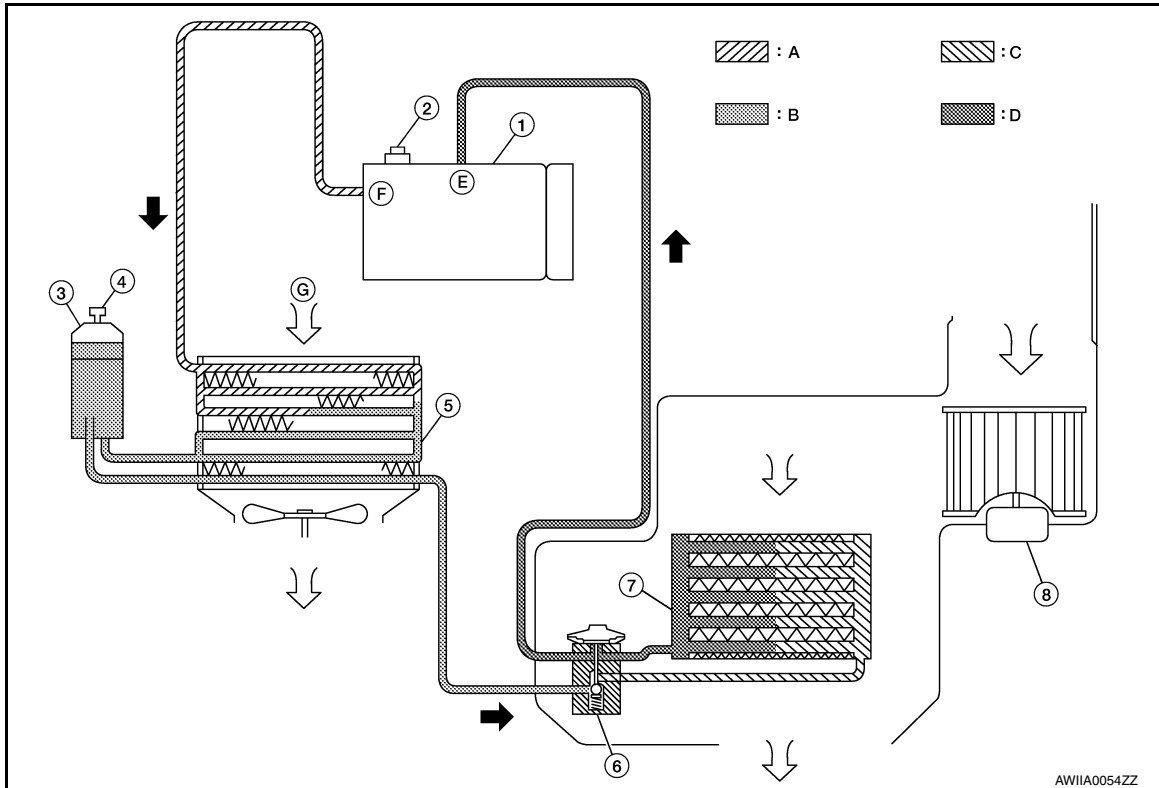

- | | | |
|--------------------------------|--------------------------|----------------------|
| 1. Electric compressor | 2. Pressure relief valve | 3. Liquid tank |
| 4. Refrigerant pressure sensor | 5. Condenser | 6. Expansion valve |
| 7. Evaporator | 8. Blower motor | A. High-pressure gas |
| B. High-pressure liquid | C. Low-pressure liquid | D. Low-pressure gas |
| E. Suction port | F. Discharge port | G. Outside air |

Refrigerant Flow

The refrigerant from the compressor flows through the condenser with liquid tank, evaporator, and returns to the compressor. The refrigerant evaporation in the evaporator is controlled by an expansion valve.

Freeze Protection

To prevent evaporator from freezing up, the evaporator air temperature is monitored and the voltage signal to the A/C auto amp. makes the A/C relay go OFF and stop the compressor.

REFRIGERATION SYSTEM

< SYSTEM DESCRIPTION >

Component Part Location

INFOID:000000012288536

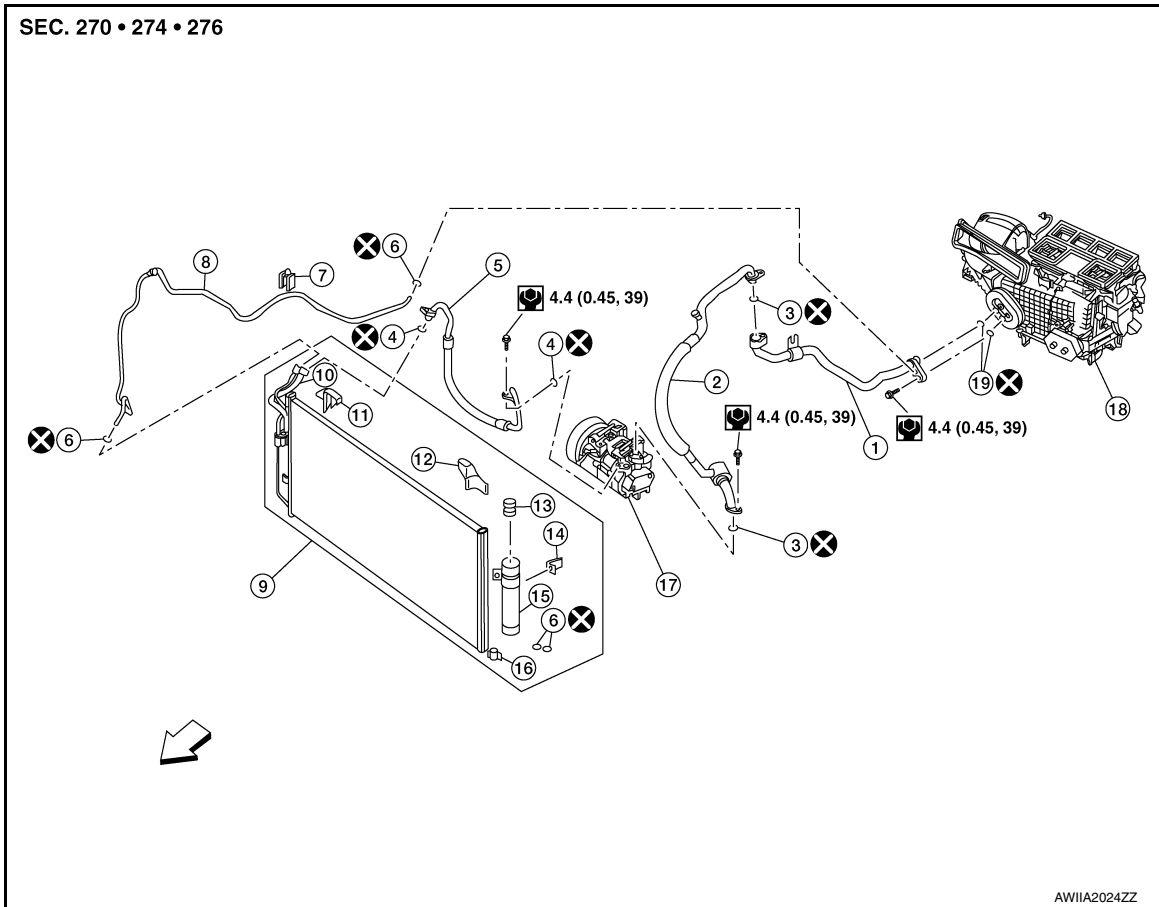

- | | | |
|-------------------------------------|--------------------------------|---------------------------------------|
| 1. Low-pressure front pipe | 2. Low-pressure flexible hose | 3. O-ring |
| 4. O-ring | 5. High-pressure flexible hose | 6. O-ring |
| 7. Insulator | 8. High-pressure front pipe | 9. Liquid tank and condenser assembly |
| 10. Condenser to tank pipe assembly | 11. Condenser bracket RH | 12. Condenser bracket LH |
| 13. Pressure sensor | 14. Liquid tank bracket | 15. Liquid tank |
| 16. Condenser bracket | 17. Compressor | 18. Heating and cooling unit assembly |
| 19. O-ring | ⇐ Front arrow | |

Refrigerant System Protection

INFOID:000000012288536

Refrigerant pressure sensor

The refrigerant system is protected against excessively high or low pressures by the refrigerant pressure sensor, located on the liquid tank. If the system pressure rises above or falls below the specifications, the refrigerant pressure sensor detects the pressure inside the refrigerant line and sends the voltage signal to the ECM. The ECM then ceases to supply power to the A/C relay which disengages and stops the compressor when the high-pressure side detected by refrigerant pressure sensor meet the following conditions.

- 3,120 KPa (31.82 kg/cm², 452.4 psi) or more (When the engine speed is less than 1,500 rpm).
- 2,740 KPa (27.95 kg/cm², 397.3 psi) or more (When the engine speed is 1,500 rpm or more).
- 140 KPa (1.43 kg/cm², 20.3 psi) or less.

Pressure Relief Valve

The refrigerant system is also protected by a pressure relief valve, located in the rear head of the compressor. When the pressure of refrigerant in the system increases to an abnormal level [more than 2,990 kPa (30.50

REFRIGERATION SYSTEM

< SYSTEM DESCRIPTION >

kg/cm², 433.6 psi)], the release port on the pressure relief valve automatically opens and releases refrigerant into the atmosphere.

A

B

C

D

E

F

G

H

HA

J

K

L

M

N

O

P

DIAGNOSIS AND REPAIR WORK FLOW

< BASIC INSPECTION >

BASIC INSPECTION

DIAGNOSIS AND REPAIR WORK FLOW

Work Flow

INFOID:000000012233582

OVERALL SEQUENCE

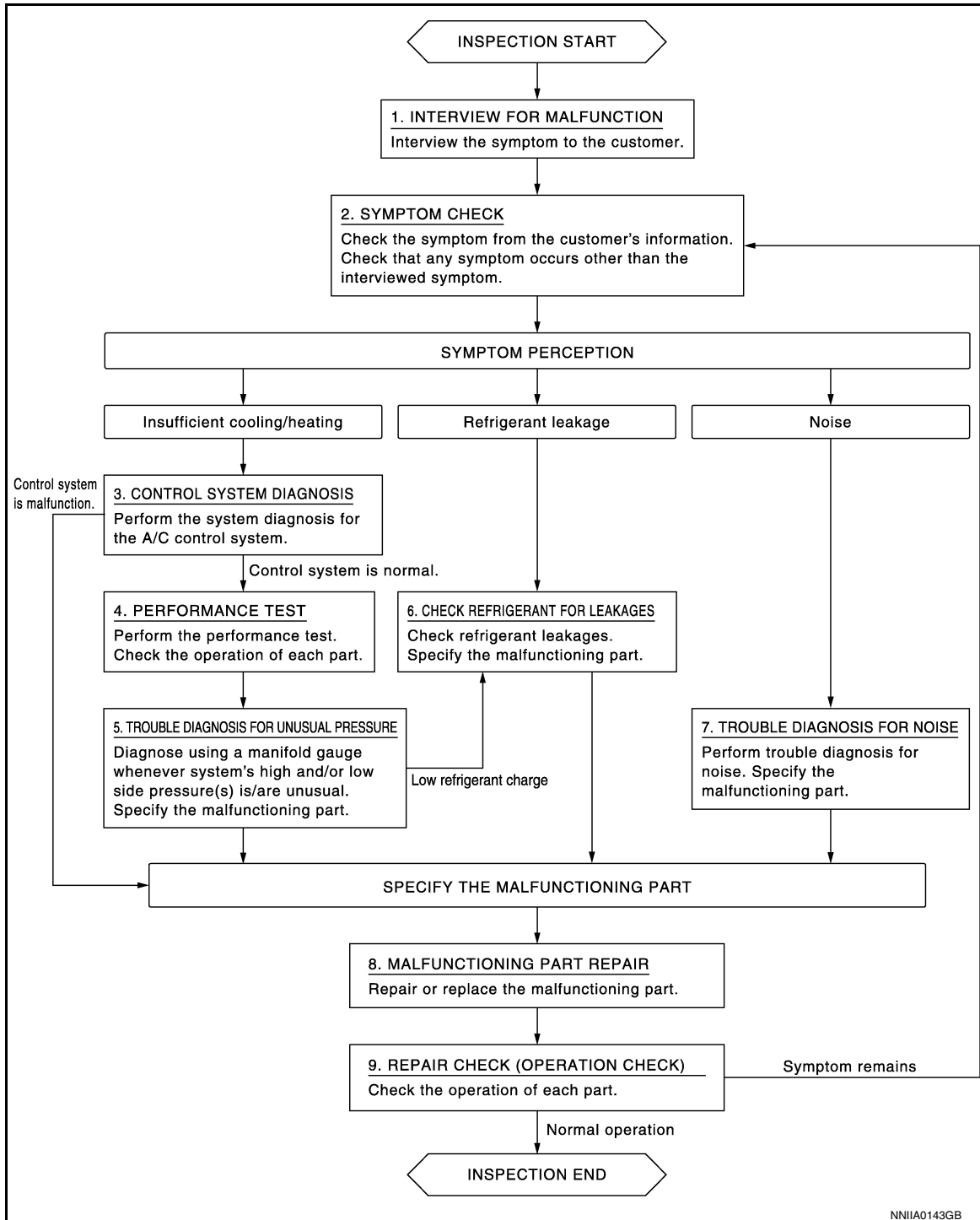

DETAILED FLOW

1. INTERVIEW FOR MALFUNCTION

Interview the symptom to the customer.

DIAGNOSIS AND REPAIR WORK FLOW

< BASIC INSPECTION >

>> GO TO 2.

2. SYMPTOM CHECK

Check the symptom from the customer's information. Check that any symptom occurs other than the interviewed symptom.

Insufficient cooling/heating>>GO TO 3.

Refrigerant leakage>>GO TO 6.

Noise >> GO TO 7.

3. CONTROL SYSTEM DIAGNOSIS

Perform the system diagnosis for the A/C control system. Refer to [HAC-43. "Work Flow"](#).

Is A/C control system normal?

YES >> GO TO 4.

NO >> GO TO 8.

4. PERFORMANCE TEST

Perform the performance test. Check the operation of each part. Refer to [HA-32. "Inspection"](#).

>> GO TO 5.

5. TROUBLE DIAGNOSIS FOR UNUSUAL PRESSURE

Diagnose using a manifold gauge whenever system's high and/or low side pressure(s) is/are unusual. Specify the malfunctioning part. Refer to [HA-18. "Trouble Diagnoses for Abnormal Pressure"](#).

Low refrigerant charge>>GO TO 6.

Except above>>GO TO 8.

6. CHECK REFRIGERANT FOR LEAKAGES

Check refrigerant for leakages. Specify the malfunctioning part. Refer to [HA-23. "Leak Test"](#).

>> GO TO 8.

7. TROUBLE DIAGNOSIS FOR NOISE

Perform trouble diagnosis for noise. Specify the malfunctioning part. Refer to [HA-22. "Symptom Table"](#).

>> GO TO 8.

8. MALFUNCTIONING PART REPAIR

Repair or replace the malfunctioning part.

>> GO TO 9.

9. REPAIR CHECK (OPERATION CHECK)

Check the operation of each part.

Does it operate normally?

YES >> Inspection End.

NO >> GO TO 2.

A
B
C
D
E
F
G
H
HA
J
K
L
M
N
O
P

REFRIGERATION SYSTEM SYMPTOMS

< SYMPTOM DIAGNOSIS >

SYMPTOM DIAGNOSIS

REFRIGERATION SYSTEM SYMPTOMS

Trouble Diagnoses for Abnormal Pressure

INFOID:000000011933668

Whenever system's high and/or low side pressure is abnormal, diagnose using a manifold gauge. The marker above the gauge scale in the following tables indicates the standard (usual) pressure range. Since the standard (usual) pressure, however, differs from vehicle to vehicle, refer to above table (Ambient air temperature-to-operating pressure table).

Both High- and Low-pressure Sides are Too High

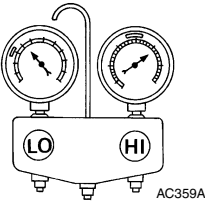
Gauge indication	Refrigerant cycle	Probable cause	Corrective action
<p>A Both high- and low-pressure sides are too high.</p>  <p>AC359A</p>	Pressure is reduced soon after water is splashed on condenser.	Excessive refrigerant charge in refrigeration cycle	Reduce refrigerant until specified pressure is obtained.
	Air suction by cooling fan is insufficient.	Insufficient condenser cooling performance ↓ 1. Condenser fins are clogged. 2. Improper fan rotation of cooling fan	<ul style="list-style-type: none"> Clean condenser. Check and repair cooling fan if necessary.
	<ul style="list-style-type: none"> Low-pressure pipe is not cold. When A/C compressor is stopped high-pressure value quickly drops by approximately 196 kPa (2 kg/cm², 28 psi). It then decreases gradually thereafter. 	Poor heat exchange in condenser (After A/C compressor operation stops, high-pressure decreases too slowly.) ↓ Air in refrigeration cycle	Evacuate and recharge system.
	Engine tends to overheat.	Engine cooling systems malfunction.	Check and repair engine cooling system.
	<ul style="list-style-type: none"> An area of the low-pressure pipe is colder than areas near the evaporator outlet. Plates are sometimes covered with frost. 	<ul style="list-style-type: none"> Excessive liquid refrigerant on low-pressure side Excessive refrigerant discharge flow Expansion valve is open a little compared with the specification. ↓ Improper expansion valve adjustment	Replace expansion valve.

High-pressure Side is Too High and Low-pressure Side is Too Low

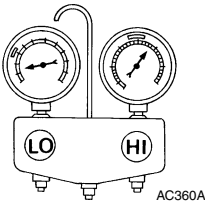
Gauge indication	Refrigerant cycle	Probable cause	Corrective action
<p>B High-pressure side is too high and low-pressure side is too low.</p>  <p>AC360A</p>	Upper side of condenser and high-pressure side are hot, however, liquid tank is not so hot.	High-pressure tube or parts located between A/C compressor and condenser are clogged or crushed.	<ul style="list-style-type: none"> Check and repair or replace malfunctioning parts. Check oil for contamination.

High-pressure Side is Too Low and Low-pressure Side is Too High

REFRIGERATION SYSTEM SYMPTOMS

< SYMPTOM DIAGNOSIS >

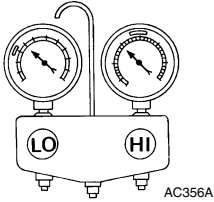
Gauge indication	Refrigerant cycle	Probable cause	Corrective action
C High-pressure side is too low and low-pressure side is too high. 	High- and low-pressure sides become equal soon after A/C compressor operation stops.	A/C compressor pressure operation is improper. ↓ Damaged inside A/C compressor packings.	Replace A/C compressor.
	No temperature difference between high- and low-pressure sides.	A/C compressor pressure operation is improper. ↓ Damaged inside A/C compressor packings.	Replace A/C compressor.

Both High- and Low-pressure Sides are Too Low

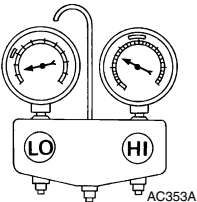
Gauge indication	Refrigerant cycle	Probable cause	Corrective action
D Both high- and low-pressure sides are too low. 	<ul style="list-style-type: none"> There is a big temperature difference between liquid tank outlet and inlet. Outlet temperature is extremely low. Liquid tank inlet and expansion valve are frosted. 	Liquid tank inside is slightly clogged.	<ul style="list-style-type: none"> Replace liquid tank. Check oil for contamination.
	<ul style="list-style-type: none"> Temperature of expansion valve inlet is extremely low as compared with areas near liquid tank. Expansion valve inlet may be frosted. Temperature difference occurs somewhere in high-pressure side. 	High-pressure pipe located between liquid tank and expansion valve is clogged.	<ul style="list-style-type: none"> Check and repair malfunctioning parts. Check oil for contamination.
	Expansion valve and liquid tank are warm or only cool when touched.	Low refrigerant charge. ↓ Leaking fittings or components.	Check refrigerant system for leaks. Refer to HA-23, "Leak Test" .
	There is a big temperature difference between expansion valve inlet and outlet while the valve itself is frosted.	Expansion valve closes a little compared with the specification. ↓ <ol style="list-style-type: none"> Improper expansion valve adjustment. Malfunctioning expansion valve. Outlet and inlet may be clogged. 	<ul style="list-style-type: none"> Remove foreign particles by using compressed air. Check oil for contamination.
	An area of the low-pressure pipe is colder than areas near the evaporator outlet.	Low-pressure pipe is clogged or crushed.	<ul style="list-style-type: none"> Check and repair malfunctioning parts. Check oil for contamination.

Low-pressure Side Sometimes Becomes Negative

REFRIGERATION SYSTEM SYMPTOMS

< SYMPTOM DIAGNOSIS >

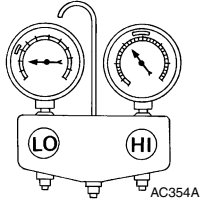
Gauge indication	Refrigerant cycle	Probable cause	Corrective action
<p>E Low-pressure side sometimes becomes negative.</p> 	<ul style="list-style-type: none"> Air conditioning system does not function and does not cyclically cool the compartment air. The system constantly functions for a certain period of time after A/C compressor is stopped and restarted. 	<p>Refrigerant does not discharge cyclically.</p> <p>↓</p> <p>Moisture is frozen at expansion valve outlet and inlet.</p> <p>↓</p> <p>Water is mixed with refrigerant.</p>	<ul style="list-style-type: none"> Drain water from refrigerant or replace refrigerant. Replace liquid tank.

Low-pressure Side Becomes Negative

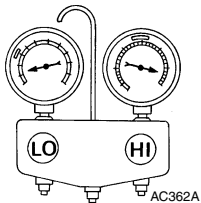
Gauge indication	Refrigerant cycle	Probable cause	Corrective action
<p>F Low-pressure side becomes negative.</p> 	<p>Liquid tank or front/rear side of expansion valve's pipe is frosted or dewed.</p>	<p>High-pressure side is closed and refrigerant does not flow.</p> <p>↓</p> <p>Expansion valve or liquid tank is frosted.</p>	<p>Leave the system at rest until no frost is present. Start it again to check whether or not the malfunction is caused by water or foreign particles.</p> <ul style="list-style-type: none"> If water is the cause, initially cooling is okay. Then the water freezes causing a blockage. Drain water from refrigerant or replace refrigerant. If due to foreign particles, remove expansion valve and remove the particles with dry and compressed air (not shop air). If either of the above methods cannot correct the malfunction, replace expansion valve. Replace liquid tank. Check oil for contamination.

Symptom Matrix Chart

INFOID:000000011933669

Symptom	Reference
A/C system cannot be controlled from the A/C switch assembly.	Go to Trouble Diagnosis Procedure for A/C System. HAC-86, "Diagnosis Procedure"
A/C display does not operate.	Go to Trouble Diagnosis Procedure for A/C display unit. HAC-76, "Diagnosis Procedure"
Air outlet does not change.	Go to Trouble Diagnosis Procedure for Mode Door Motor. (LAN) HAC-73, "Diagnosis Procedure"
Mode door motor does not operate normally.	
Discharge air temperature does not change.	Go to Trouble Diagnosis Procedure for Air Mix Door Motor. (LAN) HAC-68, "Diagnosis Procedure" (driver side) or HAC-70, "Diagnosis Procedure" (passenger side)
Air mix door motor does not operate normally.	
Intake door does not change.	Go to Trouble Diagnosis Procedure for Intake Door Motor. (LAN) HAC-74, "Diagnosis Procedure"
Intake door motor does not operate normally.	
Blower motor operation is malfunctioning.	Go to Trouble Diagnosis Procedure for Blower Motor. HAC-87, "Diagnosis Procedure"

REFRIGERATION SYSTEM SYMPTOMS

< SYMPTOM DIAGNOSIS >

Symptom	Reference	
Magnet clutch does not engage.	Go to Trouble Diagnosis Procedure for Magnet Clutch.	HAC-90. "Diagnosis Procedure"
Insufficient cooling	Go to Trouble Diagnosis Procedure for Insufficient Cooling.	HAC-95. "Diagnosis Procedure"
No cool air comes out. (Airflow volume is normal.)		
Insufficient heating	Go to Trouble Diagnosis Procedure for Insufficient Heating.	HAC-97. "Diagnosis Procedure"
No warm air comes out. (Airflow volume is normal.)		
Noise	Go to Trouble Diagnosis Procedure for Noise.	HAC-93. "Diagnosis Chart By Symptom"
Memory function does not operate.	Go to Trouble Diagnosis Procedure for Memory Function.	HAC-93. "Diagnosis Chart By Symptom"

A
B
C
D
E
F
G
H
I
J
K
L
M
N
O
P

HA

NOISE

< SYMPTOM DIAGNOSIS >

NOISE

Symptom Table

INFOID:000000012534664

Symptom	Noise source	Probable cause	Corrective action
Unusual noise from compressor when A/C is ON.	Inside of compressor	Worn, broken, or clogged internal components.	Check compressor oil. Refer to HA-27. "Inspection" .
	Magnet clutch	Contact of clutch disc with pulley.	Check clearance between clutch disc and pulley.
	Compressor body	Loose compressor mounting bolts.	Check torque of mounting bolts. Refer to HA-34. "Exploded View" .
Unusual noise from cooler piping.	Cooler piping (pipe and flexible hose)	Improper installation of clip and bracket.	Check installation of cooler piping. Refer to HA-36. "Exploded View" .
Unusual noise from expansion valve when A/C is ON.	Expansion valve	Low refrigerant charge.	<ul style="list-style-type: none"> • Check for leaks. Refer to HA-23. "Leak Test". • Recover refrigerant, evacuate system, and recharge with the specified amount of refrigerant. Refer to HA-25. "Recycle Refrigerant".
		Worn, broken, or clogged internal components.	Eliminate foreign material from expansion valve or replace it.
Unusual noise from belt.	—	Loose belt.	Check belt tension. Refer to EM-16. "Checking Drive Belt" .
		Damaged or broken components inside compressor.	Replace compressor. Refer to HA-34. "Removal and Installation" .

REFRIGERANT

< PERIODIC MAINTENANCE >

PERIODIC MAINTENANCE

REFRIGERANT

Description

INFOID:0000000011933670

CONNECTION OF SERVICE TOOLS AND EQUIPMENT

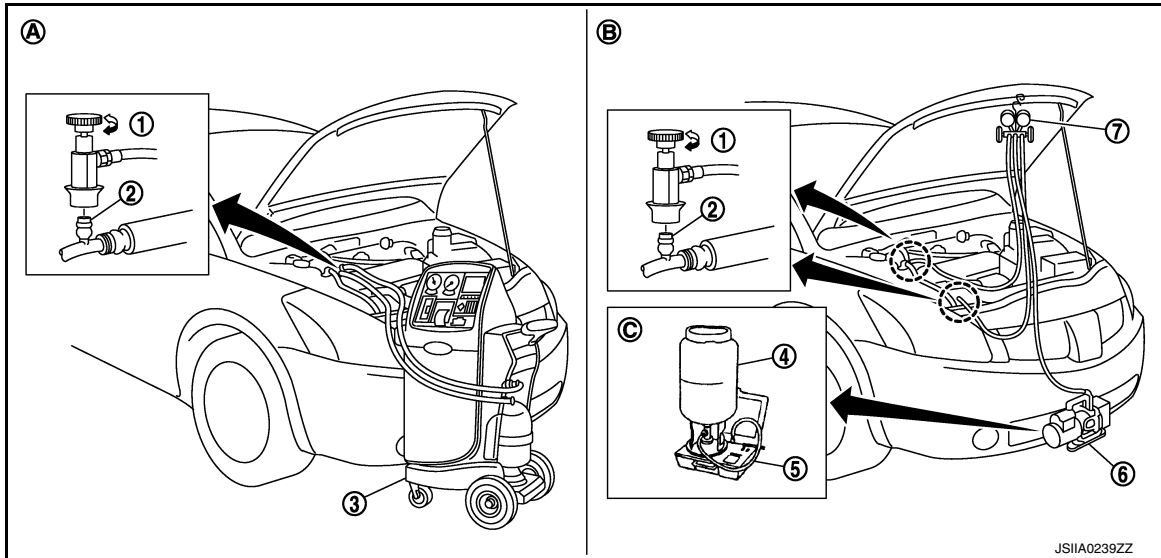

- | | | |
|-------------------------------------|----------------------------|--|
| 1. Shut-off valve | 2. A/C service valve | 3. Recovery/recycling/recharging equipment |
| 4. Refrigerant container (HFC-134a) | 5. Weight scale (J-39650) | 6. Vacuum pump (J-39649) |
| 7. Manifold gauge set (J-39183) | A. Preferred (best) method | B. Alternative method |
| C. For charging | | |

Leak Test

INFOID:0000000011933671

CHECK REFRIGERANT LEAKAGE USING FLUORESCENT LEAK DETECTION DYE

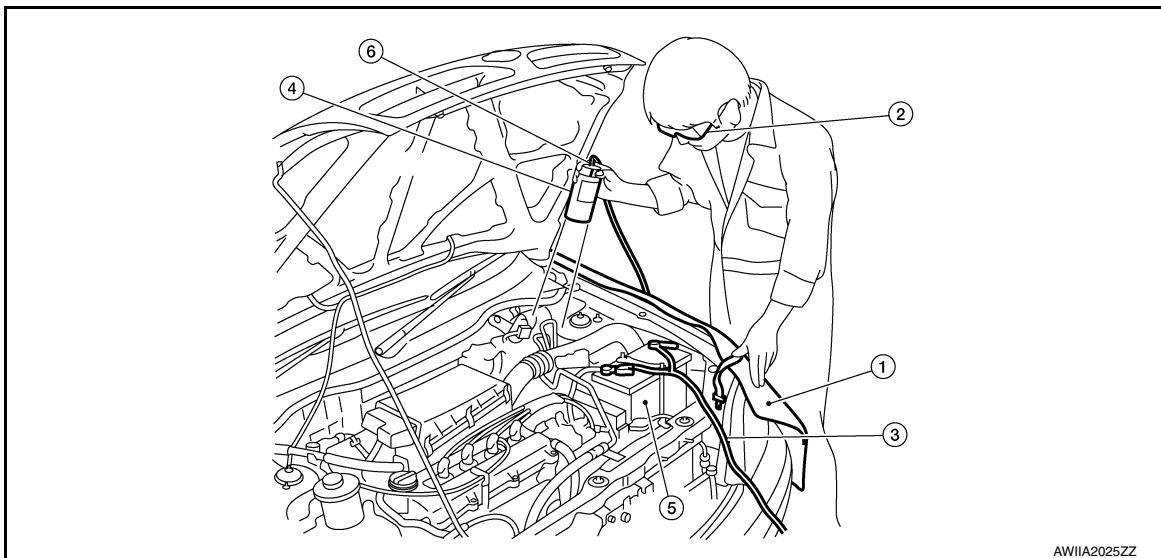

1. Install a fender cover (1).
2. Wear UV safety goggles (2) provided with refrigerant dye leak detection kit (J-43926).
3. Connect power cable (4) of UV lamp (6) to positive and negative terminals of the battery (3).

REFRIGERANT

< PERIODIC MAINTENANCE >

4. Press UV lamp switch (5) and check A/C system for refrigerant leakage. (Where refrigerant leakage occurs, fluorescent leak detection dye appears in green color.)

WARNING:

Do not look directly into UV lamp light source.

NOTE:

- For continuous operating time of UV lamp, follow the manufacturer operating instructions.
- Illuminate piping joints from different angles using UV lamp and check that there is no leakage.
- Use a mirror in area that is difficult to see to check refrigerant leakage.
- Refrigerant leakage from evaporator can be detected by soaking cotton swab or a similar material with drain hose water and illuminating it using UV lamp.
- Dust, dirt and packing materials adhesive used for condenser, evaporator, and other locations may fluoresce. Be careful not to misidentify leakage.

5. Repair or replace parts where refrigerant leakage occurs and wipe off fluorescent leak detection dye.

NOTE:

Completely wipe off fluorescent leak detection dye from gaps between parts, screw threads, and others using a cotton swab or similar materials.

6. Use a UV lamp to check that no fluorescent leak detection dye remains after finishing work.

WARNING:

Do not look directly into UV lamp light source.

NOTE:

- For continuous operating time of UV lamp, follow the manufacturer operating instructions.
- Dust, dirt, and packing materials adhesive used for condenser, evaporator, and other locations may fluoresce. Be careful not to misidentify leakage.

CHECK REFRIGERANT LEAKAGE USING ELECTRICAL LEAK DETECTOR

WARNING:

Do not check refrigerant leakage while the engine is running.

CAUTION:

Be careful of the following items so that inaccurate checks or misidentifications are avoided.

- **Do not allow refrigerant vapor, shop chemical vapors, cigarette smoke or others around the vehicle.**
- **Always check refrigerant leakage in a low air flow environment so that refrigerant may not disperse when leakage occurs.**

1. Stop the engine.
2. Connect recovery/recycling/recharging equipment or manifold gauge set (J-39183-C) to A/C service valve.
3. Check that A/C refrigerant pressure is 345 kPa (3.52 kg/cm², 50 psi) or more when temperature is 16°C (61°F) or more. When pressure is lower than the specified value, recycle refrigerant completely and fill refrigerant to the specified level.

NOTE:

Leakages may not be detected if A/C refrigerant pressure is 345 kPa (3.52 kg/cm², 50 psi) or less when temperature is less than 16°C (61°F).

4. Clean area where refrigerant leakage check is performed and check refrigerant leakage along all surfaces of pipe connections and A/C system components using electrical leak detector (J-41995) probe.

CAUTION:

- **Continue checking when a leakage is found. Always continue and complete checking along all pipe connections and A/C system components for additional leakage.**
- **When a leakage is detected, clean leakage area using compressed air and check again.**
- **When checking leakage of cooling unit inside, always clean inside of drain hose so that the probe surface may not be exposed to water or dirt.**

NOTE:

- Always check leakage starting from high-pressure side and continue to low-pressure side.
- When checking leakage of cooling unit inside, operate blower fan motor for 15 minutes or more at the maximum fan speed while the engine is stopped, and then insert electrical leak detector probe into drain hose and hold for 10 minutes or more.
- When disconnecting shut-off valve that is connected to A/C service valve, always evacuate remaining refrigerant so that misidentification can be avoided.

5. Repair or replace parts where refrigerant leakage is detected. (Leakage is detected but leakage area is unknown.)

REFRIGERANT

< PERIODIC MAINTENANCE >

- Start the engine and set A/C control in the following conditions.
 - A/C switch ON
 - Air flow: VENT (ventilation)
 - Intake door position: Recirculation
 - Temperature setting: Full cold
 - Fan (blower) speed: Maximum speed set
- Run the engine at approximately 1,500 rpm for 2 minutes or more.
- Stop the engine. Check again for refrigerant leakage. Go to step 4.

WARNING:

Be careful not to get burned when the engine is hot.

NOTE:

- Start refrigerant leakage check immediately after the engine is stopped.
- When refrigerant circulation is stopped, pressure on the low-pressure side rises gradually, and after this, pressure on the high-pressure side falls gradually.
- The higher the pressure is, the easier it is to find the refrigerant leakage.

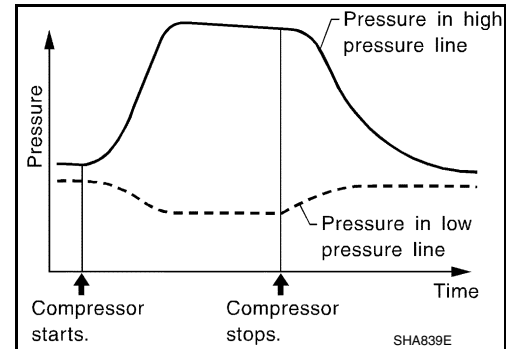

Recycle Refrigerant

INFOID:000000011933672

WARNING:

- Always use HFC-134a for A/C refrigerant. If CFC-12 is accidentally charged, compressor is damaged due to insufficient lubrication.
- Always observe and follow precautions described on refrigerant container. Incorrect handling may result in an explosion of refrigerant container, frostbite or the loss of eyesight.
- Do not breathe A/C refrigerant and oil vapor or mist. Exposure may irritate eyes, nose, or throat.
- Do not allow HFC-134a to be exposed to an open flame or others because it generates poisonous gas when in contact with high temperature objects. Keep workshop well ventilated.

- Perform oil return operation. Refer to [HA-27, "Perform Oil Return Operation"](#). (If refrigerant or oil leakage is detected in a large amount, omit this step, and go to step 2.)

CAUTION:

Do not perform oil return operation if a large amount of refrigerant or oil leakage is detected.

- Check gauge pressure readings of recovery/recycling/recharging equipment. When remaining pressure exists, recycle refrigerant from high-pressure hose and low-pressure hose.

NOTE:

Follow manufacturer instructions for the handling or maintenance of the equipment. Do not fill the equipment with non-specified refrigerant.

- Remove A/C service valve cap from the vehicle.
- Connect recovery/recycling/recharging equipment to A/C service valve.
- Operate recovery/recycling/recharging equipment, and recycle refrigerant from the vehicle.
- Evacuate air for 10 minutes or more to remove any remaining refrigerant integrated to compressor oil, etc.
- Refrigerant recycle operation is complete.

Charge Refrigerant

INFOID:000000011933673

WARNING:

- Always use HFC-134a for A/C refrigerant. If CFC-12 is accidentally charged, compressor is damaged due to insufficient lubrication.
- Always observe and follow precautions described on refrigerant container. Incorrect handling may result in an explosion of refrigerant container, frostbite, or the loss of eyesight.
- Do not breathe A/C refrigerant and oil vapor or mist. Exposure may irritate eyes, nose, or throat.
- Do not allow HFC-134a to be exposed to an open flame or others because it generates poisonous gas when in contact with high temperature objects. Keep workshop well ventilated.

REFRIGERANT

< PERIODIC MAINTENANCE >

1. Connect recovery/recycling/recharging equipment to the A/C service valve.
2. Operate recovery/recycling/recharging equipment, and evacuate air from A/C system for 25 minutes or more.
CAUTION:
Evacuate air for 15 minutes or more if the parts are replaced.
3. Check the airtightness of A/C system for 25 minutes or more. If pressure raises more than the specified level, charge A/C system with approximately 200g refrigerant and check that there is no refrigerant leakage. Refer to [HA-23, "Leak Test"](#).
CAUTION:
Check the airtightness for 15 minutes or more if the parts are replaced.
4. If parts other than compressor are replaced, fill compressor oil according to parts that are replaced.
5. Charge the specified amount of refrigerant to A/C system.
6. Check that A/C system operates normally.
7. Disconnect recovery/recycling/recharging equipment. (Collect the refrigerant from the high-pressure hose and low-pressure hose of recovery/recycling/recharging equipment.)
8. Install A/C service valve cap.
9. Refrigerant charge is complete.

OIL

< PERIODIC MAINTENANCE >

OIL

Description

INFOID:0000000011933674

MAINTENANCE OF OIL LEVEL

The compressor oil is circulating in the system together with the refrigerant. It is necessary to fill compressor with oil when replacing A/C system parts or when a large amount of refrigerant leakage is detected. It is important to always maintain oil level within the specified level, otherwise the following conditions may occur:

- Insufficient oil amount: Stuck compressor
- Excessive oil amount: Insufficient cooling (caused by insufficient heat exchange)

Oil Type : **HA-47, "Oil"**

Inspection

INFOID:0000000011933675

If a compressor is malfunctioning (internal noise, insufficient cooling), check the compressor oil.

1. COMPRESSOR OIL JUDGMENT

1. Remove the compressor. Refer to [HA-34, "Removal and Installation"](#).
2. Sample compressor oil and judge below according to the figure.

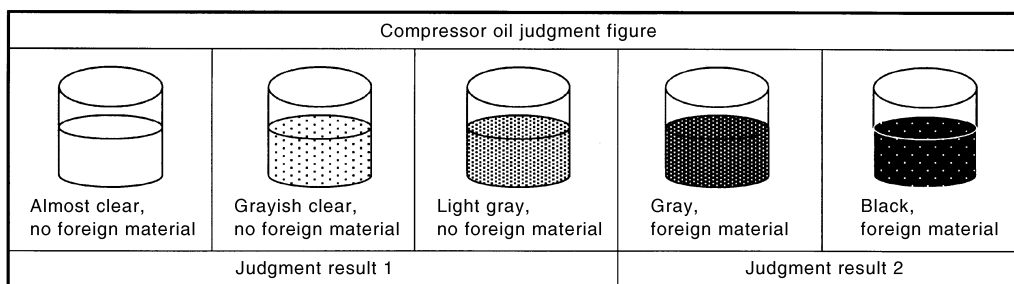

JSIIA0927GB

Judgement result 1>>Replace compressor only.

Judgement result 2>>Replace compressor and liquid tank.

Perform Oil Return Operation

INFOID:0000000011933676

CAUTION:

If a large amount of refrigerant or oil leakage is detected, do not perform oil return operation.

1. Start the engine and set to the following conditions:
 - Engine speed: Idling to 1,200 rpm
 - A/C switch: ON
 - Fan (blower) speed: Maximum speed set
 - Intake door position: Recirculation
 - Temperature setting: Full cold
2. Perform oil return operation for approximately 10 minutes.
3. Stop the engine.
4. Oil return operation is complete.

Oil Adjusting Procedure for Components Replacement Except Compressor

INFOID:0000000011933677

Fill with oil for the amount that is calculated according to the following conditions.

Example: Oil amount to be added when replacing evaporator and liquid tank [m ℓ (US fl oz, Imp fl oz)] = 45 (1.5, 1.6) + 15 (0.5, 0.5) + α

Conditions	Oil amount to be added to A/C system m ℓ (US fl oz, Imp fl oz)
Replace evaporator	75 (2.5, 2.6)
Replace condenser	75 (2.5, 2.6)

OIL

< PERIODIC MAINTENANCE >

Conditions		Oil amount to be added to A/C system m ℓ (US fl oz, Imp fl oz)
Replace liquid tank		5 (0.2, 0.2)
Refrigerant leakage is detected	Large amount leakage	30 (1.0, 1.1)
	Small amount leakage	—
Oil amount that is recycled together with refrigerant during recycle operation		α

Oil Adjusting Procedure for Compressor Replacement

INFOID:0000000011933678

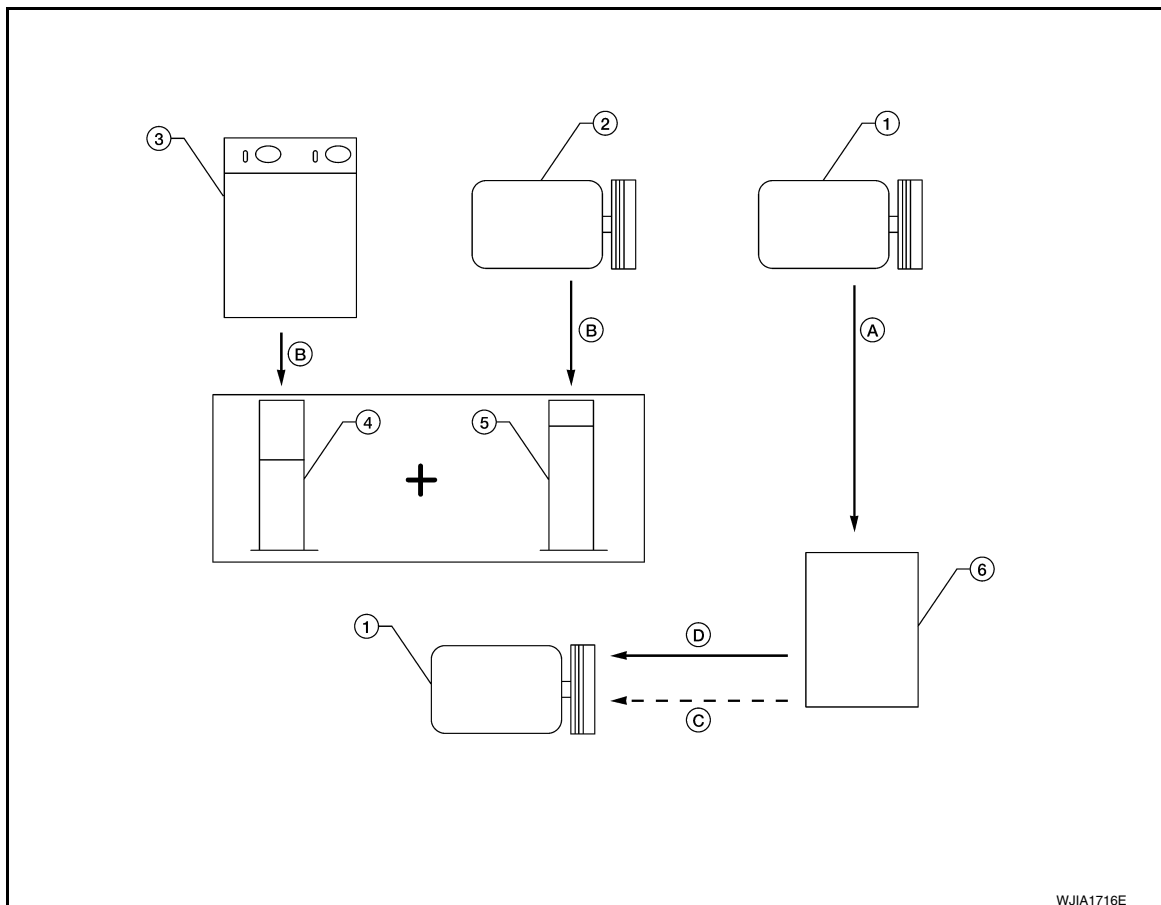

WJIA1716E

- | | | |
|---|-----------------------------------|--|
| 1. New compressor | 2. Old compressor | 3. Recovery/recycling equipment |
| 4. Measuring cup X | 5. Measuring cup Y | 6. New oil |
| A. Drain oil from the new compressor into clean container | B. Record amount of oil recovered | C. Add an additional 5 m ℓ (0.2 US fl oz, 0.2 Imp fl oz) of new oil when replacing liquid tank |
| D. Install new oil equal to recorded amounts in measuring cups X plus Y | | |

- Before connecting recovery/recycling equipment to vehicle, check recovery/recycling equipment gauges. No refrigerant pressure should be displayed. If NG, recover refrigerant from equipment lines.
- Connect recovery/recycling equipment to vehicle. Confirm refrigerant purity in supply tank using recovery/recycling equipment and refrigerant identifier. If NG, refer to [HA-4, "Precaution for Working with HFC-134a \(R-134a\)"](#).
- Confirm refrigerant purity in vehicle A/C system using recovery/recycling equipment and refrigerant identifier. If NG, refer to [HA-4, "Precaution for Working with HFC-134a \(R-134a\)"](#).
- Discharge refrigerant into the refrigerant recovery/recycling equipment. Measure oil discharged into the recovery/recycling equipment.

OIL

< PERIODIC MAINTENANCE >

5. Drain the oil from the “old” (removed) compressor into a graduated container and recover the amount of oil drained. A
6. Drain the oil from the “new” compressor into a separate, clean container.
7. Measure an amount of new oil installed equal to amount drained from “old” compressor. Add this oil to “new” compressor through the suction port opening. B
8. Measure an amount of new oil equal to the amount recovered during discharging. Add this oil to “new” compressor through the suction port opening.
9. If the liquid tank also needs to be replaced, add an additional 5 m ℓ (0.2 US fl oz, 0.2 Imp fl oz) of oil at this time. C

CAUTION:

Do not add the 5 m ℓ (0.2 US fl oz, 0.2 Imp fl oz) of oil if only replacing the compressor and not the liquid tank. D

E

F

G

H

HA

J

K

L

M

N

O

P

REFRIGERATION SYSTEM

< PERIODIC MAINTENANCE >

REFRIGERATION SYSTEM

Inspection

INFOID:000000011933679

1. CHECK BLOWER MOTOR OPERATION

Check blower motor operation. Refer to [HAC-87, "Diagnosis Procedure"](#).

Is the inspection result normal?

YES >> GO TO 2.

NO >> Repair or replace the parts according to the inspection results.

2. CHECK COMPRESSOR OPERATION

Check compressor operation. Refer to [HAC-90, "Component Function Check"](#).

Is the inspection result normal?

YES >> GO TO 3.

NO >> Repair or replace the parts according to the inspection results.

3. CHECK REFRIGERANT CYCLE PRESSURE

Connect recovery/recycling/recharging equipment to the vehicle and perform the diagnosis with the gauge pressure. Refer to [HA-18, "Trouble Diagnoses for Abnormal Pressure"](#) (with color display) or [HA-18, "Trouble Diagnoses for Abnormal Pressure"](#) (with monochrome display).

Is the inspection result normal?

YES >> Perform the performance test. Refer to [HA-30, "Performance Chart"](#).



NO >> Repair or replace the parts according to the inspection results.

Performance Chart

INFOID:000000011933680

TEST CONDITION

Testing must be performed as follows:

Vehicle location	Indoors or in the shade (in a well-ventilated place)
Doors	Closed
Door windows	Open
Hood	Open
TEMP.	Max. COLD
Mode switch	 (Ventilation) set
Intake switch	 (Recirculation) set
 (fan) speed	Max. speed set
Engine speed	Idle speed

Operate the air conditioning system for 10 minutes before taking measurements.

TEST READING

Recirculating-to-discharge Air Temperature Table

Inside air (Recirculating air) at blower assembly inlet		Discharge air temperature at center ventilator °C (°F)
Relative humidity %	Air temperature °C (°F)	
50 - 60	25 (77)	10.0 - 12.3 (50 - 54)
	30 (86)	13.2 - 15.3 (56 - 60)
	35 (95)	17.2 - 21.0 (63 - 70)

REFRIGERATION SYSTEM

< PERIODIC MAINTENANCE >

Inside air (Recirculating air) at blower assembly inlet		Discharge air temperature at center ventilator °C (°F)	A
Relative humidity %	Air temperature °C (°F)		
60 - 70	25 (77)	12.3 - 14.9 (54 - 59)	B
	30 (86)	15.3 - 19.3 (60 - 67)	
	35 (95)	21.0 - 24.4 (70 - 76)	C

Ambient Air Temperature-to-operating Pressure Table

Ambient air		High-pressure (Discharge side) kPa (kg/cm2, psi)	Low-pressure (Suction side) kPa (kg/cm2, psi)	D
Relative humidity %	Air temperature °C (°F)			
50 - 70	30 (86)	1,220 - 1,500 (12.44 - 15.30, 176.9 - 217.5)	240 - 295 (2.45 - 3.01, 34.8 - 42.8)	E
	35 (95)	1,360 - 1,690 (13.87 - 17.24, 197.2 - 245.1)	275 - 335 (2.81 - 3.42, 39.9 - 48.6)	
	40 (104)	1,500 - 1,830 (12.44 - 18.67, 176.9 - 265.4)	310 - 375 (3.16 - 3.83, 45.0 - 54.4)	F

A
B
C
D
E
F
G
H
HA
J
K
L
M
N
O
P

HA

PERFORMANCE TEST

< PERIODIC MAINTENANCE >

PERFORMANCE TEST

Inspection

INFOID:000000011933681

INSPECTION PROCEDURE

1. Connect recovery/recycling/recharging equipment (for HFC-134a) or manifold gauge.
2. Start the engine, and set to the following condition.

Test condition		
Surrounding condition		Indoors or in the shade (in a well-ventilated place)
Vehicle condition	Door	Closed
	Door glass	Full open
	Hood	Open
	Engine speed	Idle speed
A/C condition	Temperature control switch or dial	Full cold
	A/C switch	ON
	Air outlet	VENT (ventilation)
	Intake door position	Recirculation
	Fan (blower) speed	Maximum speed set

3. Maintain test condition until A/C system becomes stable. (Approximately 10 minutes)
4. Check that test results of “recirculating-to-discharge air temperature” and “ambient air temperature-to-operating pressure” are within the specified value.
5. When test results are within the specified value, inspection is complete.
If any of test result is out of the specified value, perform diagnosis by gauge pressure. Refer to [HA-20, "Symptom Matrix Chart"](#).

RECIRCULATING-TO-DISCHARGE AIR TEMPERATURE TABLE

Inside air (Recirculating air) at blower assembly inlet		Discharge air temperature from center ventilator °C (°F)
Relative humidity %	Air temperature °C (°F)	
50 – 60	20 (68)	4.7 – 6.7 (40 – 44)
	25 (77)	8.6 – 11.1 (47 – 52)
	30 (86)	12.6 – 15.6 (55 – 60)
	35 (95)	19.0 – 22.5 (66 – 73)
60 – 70	20 (68)	6.7 – 8.7 (44 – 48)
	25 (77)	11.1 – 13.6 (52 – 56)
	30 (86)	15.6 – 18.6 (60 – 65)
	35 (95)	22.5 – 26.0 (73 – 79)

AMBIENT AIR TEMPERATURE-TO-OPERATING PRESSURE TABLE

PERFORMANCE TEST

< PERIODIC MAINTENANCE >

Fresh air		High-pressure (Discharge side) kPa (kg/cm ² , psi)	Low-pressure (Suction side) kPa (kg/cm ² , psi)	A
Relative humidity %	Air temperature °C (°F)			
50 – 70	25 (77)	909 – 1,112 (9.2 – 11.3, 131.8 – 161.2)	159 – 194 (1.6 – 2.0, 23.1 – 28.1)	B
	30 (86)	1,073 – 1,312 (10.9 – 13.4, 155.6 – 190.2)	211 – 259 (2.2 – 2.6, 30.6 – 37.6)	C
	35 (95)	1,445 – 1,766 (14.7 – 18.0, 209.5 – 256.1)	247 – 300 (2.5 – 3.1, 35.8 – 43.5)	D
	40 (104)	1,650 – 2,017 (16.8 – 20.6, 239.3 – 292.5)	290 – 355 (3.0 – 3.6, 42.1 – 51.5)	E

F

G

H

HA

I

J

K

L

M

N

O

P

COMPRESSOR

< REMOVAL AND INSTALLATION >

REMOVAL AND INSTALLATION

COMPRESSOR

Exploded View

INFOID:000000012290440

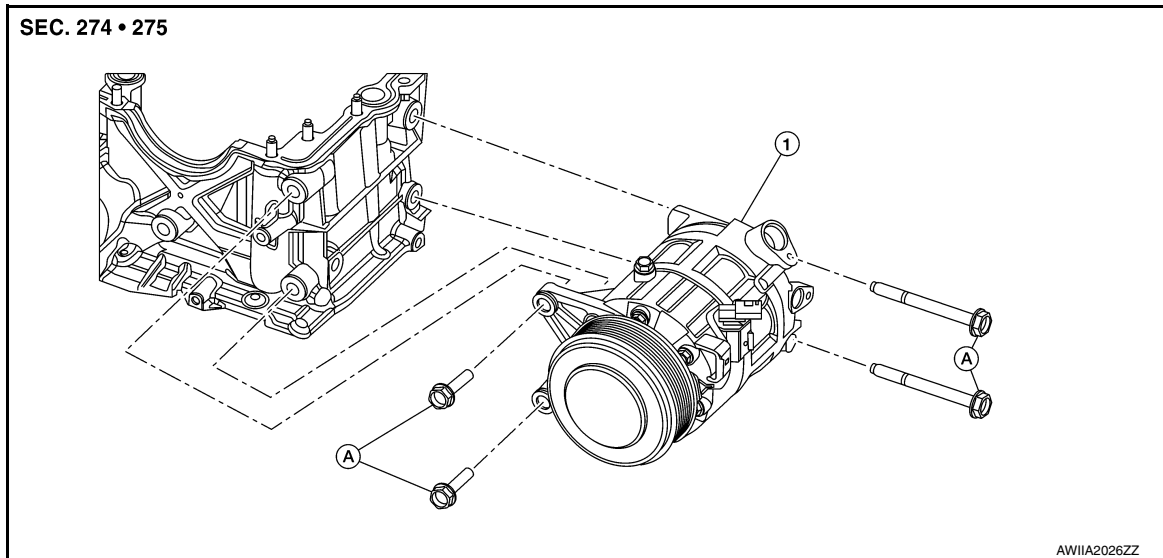

1. Compressor

A. Refer to INSTALLATION

Removal and Installation

INFOID:000000012290441

REMOVAL

1. Discharge the refrigerant. Refer to [HA-25, "Recycle Refrigerant"](#).
2. Remove the tire and wheel. Refer to [WT-67, "Removal and Installation"](#).
3. Remove the front under cover. Refer to [EXT-26, "Removal and Installation"](#).
4. Remove the fender protector (RH). Refer to [EXT-26, "Removal and Installation"](#).
5. Remove the drive belt. Refer to [EM-16, "Removal and Installation"](#).
6. Remove the drive belt auto-tensioner. Refer to [EM-18, "Removal and Installation of Drive Belt Auto-tensioner"](#).
7. Disconnect the oil pressure sensor electrical connector, then position the wiring harness aside.
8. Disconnect the A/C high side line from the compressor.
CAUTION:
Cap or wrap the joint of the A/C pipes with suitable material such as vinyl tape to avoid the entry of air.
9. Disconnect the A/C low side line from the compressor.
CAUTION:
Cap or wrap the joint of the A/C pipes with suitable material such as vinyl tape to avoid the entry of air.
10. Disconnect the electrical connectors from the compressor.
11. Remove the 2 oil cooler line bracket bolts and position the bracket aside.

COMPRESSOR

< REMOVAL AND INSTALLATION >

12. Remove the compressor bolts and the compressor.

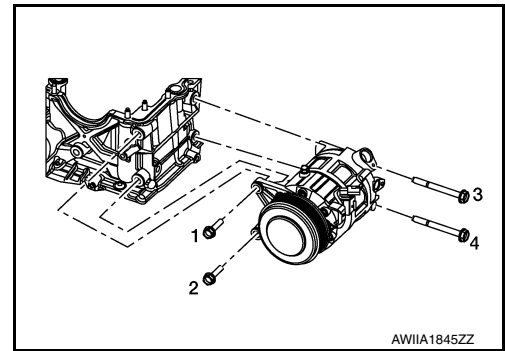

INSTALLATION

Installation is in the reverse order of removal. Follow the procedure below for specific tightening sequences and procedures.

1. Install the compressor bolts in two steps in the numerical order as shown.

Step 1 : 55.0 (5.6 kg-m, 41 ft-lb)

Step 2 : 61.3 (6.3 kg-m, 45 ft-lb)

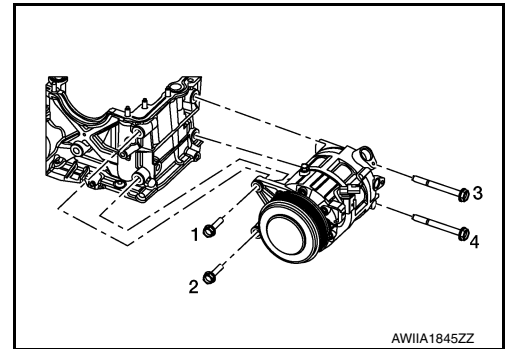

CAUTION:

- Do not reuse the O-rings.
- Apply A/C compressor oil to the new O-rings for installation.
- After charging the A/C refrigerant, check for leaks. Refer to [HA-23, "Leak Test"](#).

INSPECTION AFTER INSTALLATION

Check the clearance (B) all the way around between the clutch disc (1) and pulley (2) using a suitable tool (A) as shown.

Clutch disc-to-pulley clearance (B)

Refer to [HA-47, "Compressor"](#).

If the specified clearance (B) is not obtained, replace the adjusting shim(s) and recheck the clearance (B) as shown.

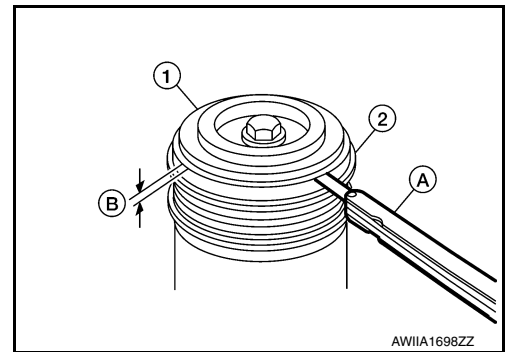

INFOID:000000012290442

Removal and Installation

REMOVAL

The Magnet clutch is not available separately and must be replaced with the compressor unit as an assembly. Refer to [HA-34, "Exploded View"](#).

COOLER PIPE AND HOSE

< REMOVAL AND INSTALLATION >

COOLER PIPE AND HOSE

Exploded View

INFOID:000000011933684

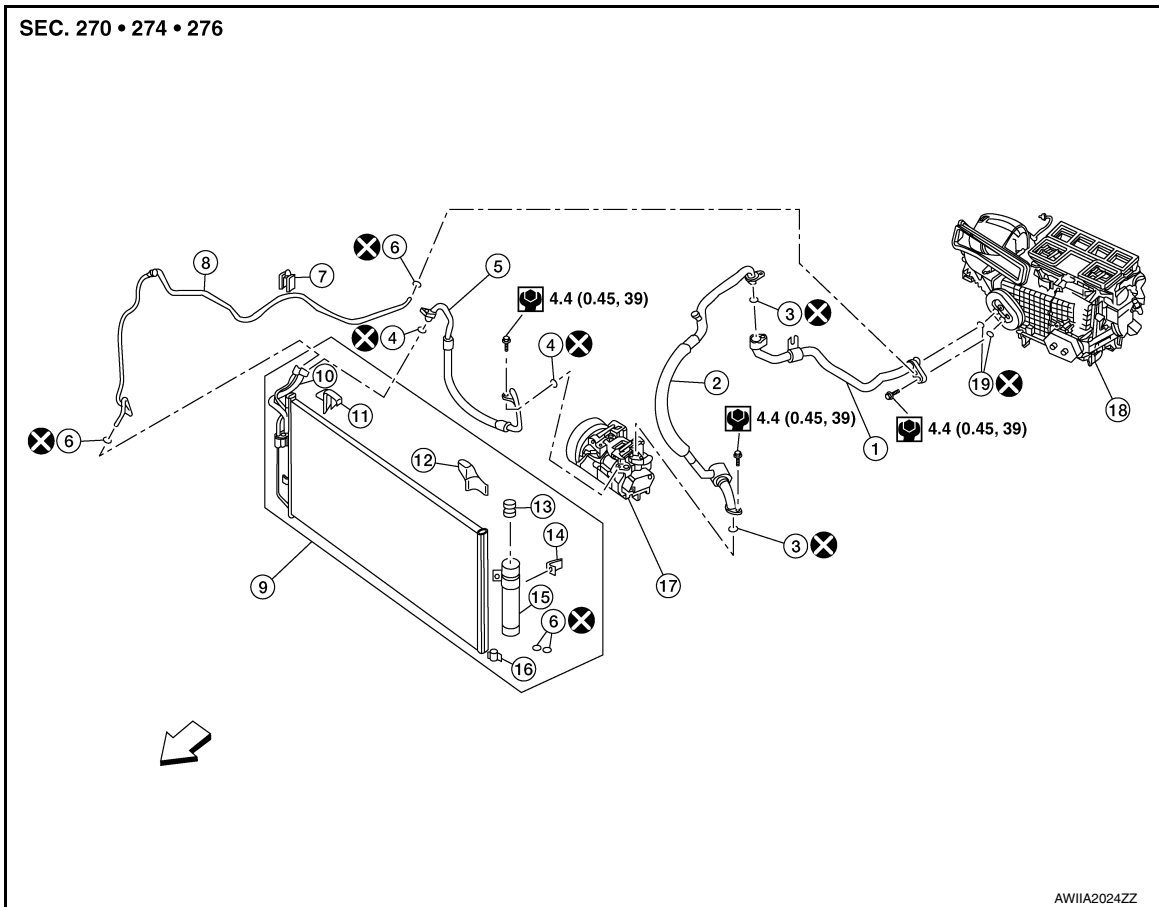

- | | | |
|-------------------------------------|--------------------------------|---------------------------------------|
| 1. Low-pressure front pipe | 2. Low-pressure flexible hose | 3. O-ring |
| 4. O-ring | 5. High-pressure flexible hose | 6. O-ring |
| 7. Insulator | 8. High-pressure front pipe | 9. Liquid tank and condenser assembly |
| 10. Condenser to tank pipe assembly | 11. Condenser bracket RH | 12. Condenser bracket LH |
| 13. Pressure sensor | 14. Liquid tank bracket | 15. Liquid tank |
| 16. Condenser bracket | 17. Compressor | 18. Heating and cooling unit assembly |
| 19. O-ring | ↩ Front arrow | |

LOW-PRESSURE FLEXIBLE HOSE

LOW-PRESSURE FLEXIBLE HOSE : Removal and Installation

INFOID:000000011933685

REMOVAL

1. Discharge the refrigerant. Refer to [HA-25. "Recycle Refrigerant"](#).
2. Partially drain the engine cooling system. Refer to [CO-12. "Changing Engine Coolant"](#).
3. Remove the engine room cover.
4. Disconnect the upper radiator hose.

COOLER PIPE AND HOSE

< REMOVAL AND INSTALLATION >

5. Remove the bolt (A) that retains the low-pressure flexible hose to the low-pressure pipe.

CAUTION:

Cap or wrap the joint of the hose with suitable material such as vinyl tape to avoid the entry of air.

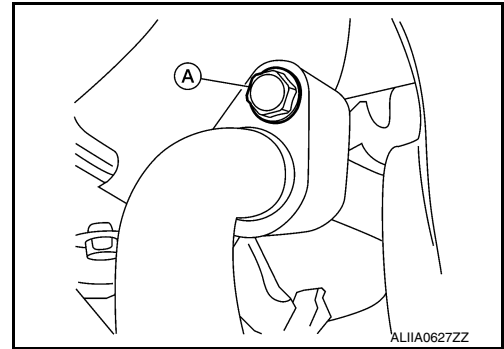

6. Disconnect ground wire (A) from front of engine.

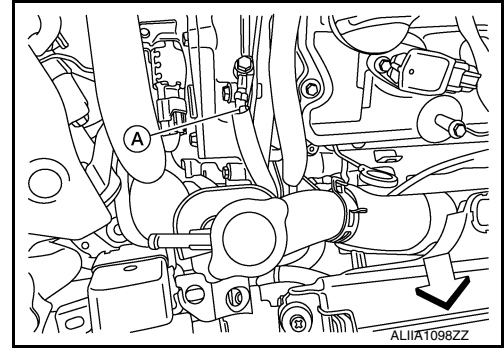

7. Disconnect the low-pressure flexible hose from the compressor and the low-pressure pipe.

CAUTION:

Cap or wrap the joint of the hose with suitable material such as vinyl tape to avoid the entry of air.

8. Remove the low-pressure flexible hose.

INSTALLATION

Installation is in the reverse order of removal.

CAUTION:

- Do not reuse O-rings.
- Apply A/C oil to the new O-rings for installation.
- After recharging the refrigerant, check for leaks. Refer to [HA-23, "Leak Test"](#).

LOW-PRESSURE PIPE

LOW-PRESSURE PIPE : Removal and Installation

INFOID:000000011933686

REMOVAL

1. Discharge the refrigerant. Refer to [HA-25, "Recycle Refrigerant"](#).
2. Remove the bolt (A) that retains the low-pressure pipe to the expansion valve.

CAUTION:

Cap or wrap the joint of the pipe with a suitable material such as vinyl tape to avoid the entry of air.

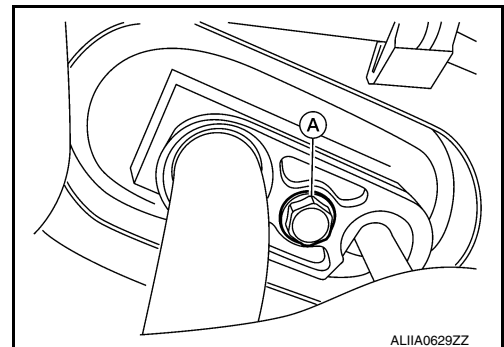

3. Remove high-pressure piping (upper) and low-pressure piping (upper) from the power steering pump assembly. Refer to [ST-44, "Exploded View"](#).

COOLER PIPE AND HOSE

< REMOVAL AND INSTALLATION >

4. Remove bolt (A) that retains the low-pressure pipe to the low-pressure hose.

CAUTION:

Cap or wrap the joint of the pipe with a suitable material such as vinyl tape to avoid the entry of air.

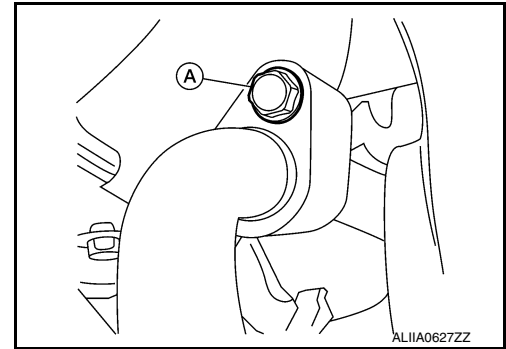

5. Remove the low-pressure pipe.

INSTALLATION

Installation is in the reverse order of removal.

CAUTION:

- Do not reuse O-rings.
- Apply A/C oil to the new O-rings for installation.
- After recharging the refrigerant, check for leaks. Refer to [HA-23, "Leak Test"](#).

HIGH-PRESSURE FLEXIBLE HOSE

HIGH-PRESSURE FLEXIBLE HOSE : Removal and Installation

INFOID:000000011933687

REMOVAL

CAUTION:

Before servicing, turn the ignition switch off, disconnect both battery terminals and wait at least three minutes.

1. Discharge the refrigerant. Refer to [HA-25, "Recycle Refrigerant"](#).
2. Remove the bolt (A) that retains the high-pressure flexible hose to the condenser pipe.

CAUTION:

Cap or wrap the joint of the hose with suitable material such as a vinyl tape to avoid the entry of air.

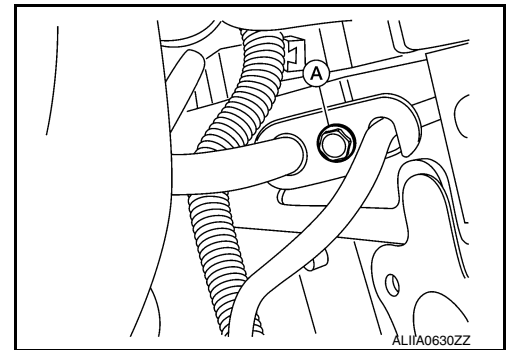

3. Disconnect the high-pressure flexible hose from the compressor and the high-pressure pipe and junction pipe.

CAUTION:

Cap or wrap the joint of the hose with suitable material such as vinyl tape to avoid the entry of air.

4. Remove the high-pressure flexible hose.

INSTALLATION

Installation is in the reverse order of removal.

CAUTION:

- Do not reuse O-rings.
- Apply A/C oil to the new O-rings for installation.
- After charging the refrigerant, check for leaks. Refer to [HA-23, "Leak Test"](#).

HIGH-PRESSURE PIPE

HIGH-PRESSURE PIPE : Removal and Installation

INFOID:000000011933688

REMOVAL

COOLER PIPE AND HOSE

< REMOVAL AND INSTALLATION >

1. Discharge the refrigerant. Refer to [HA-25. "Recycle Refrigerant"](#).
2. Remove the hoodedge covers (LH/RH).
3. Remove power steering pump assembly. Refer to [ST-43. "Removal and Installation"](#).
4. Remove the cowl top. Refer to [EXT-25. "Removal and Installation"](#).
5. Remove coolant overflow reservoir tube (A).
6. Remove coolant overflow reservoir bolt (B).
7. Remove coolant overflow reservoir (1).

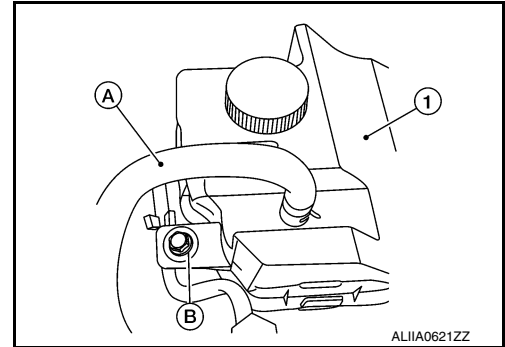

8. Remove the upper torque rod. Refer to [EM-107. "Removal and Installation"](#).

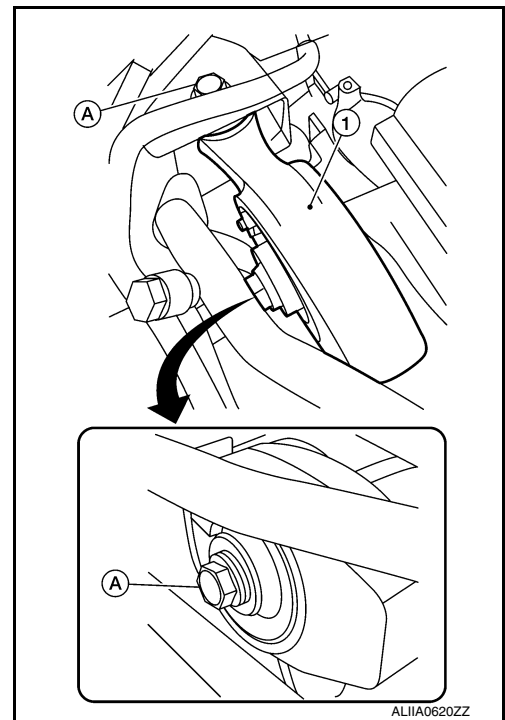

9. Remove bolt (A) that retains the high-pressure pipe to the expansion valve.

CAUTION:

Cap or wrap the joint of the pipe with a suitable material such as vinyl tape to avoid the entry of air.

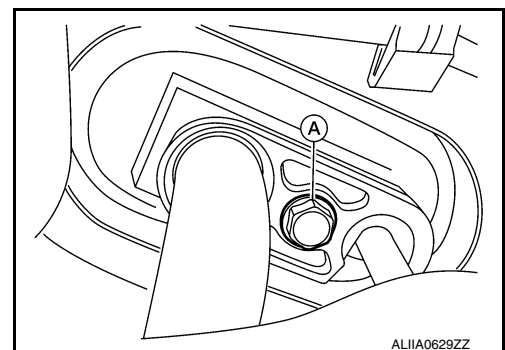

A
B
C
D
E
F
G
H
HA
J
K
L
M
N
O
P

COOLER PIPE AND HOSE

< REMOVAL AND INSTALLATION >

10. Remove the bolt (A) that retains the high-pressure pipe to the condenser pipe.

CAUTION:

Cap or wrap the joint of the pipe with a suitable material such as vinyl tape to avoid the entry of air.

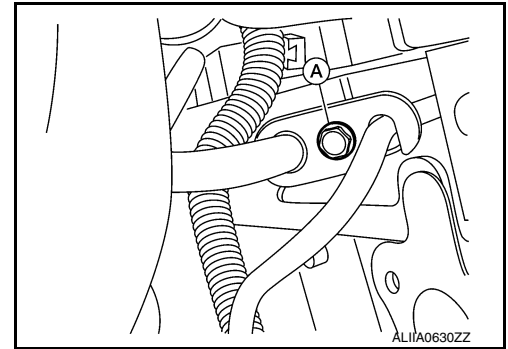

INSTALLATION

Installation is in the reverse order of removal.

CAUTION:

- Do not reuse O-rings.
- Apply A/C oil to the new O-rings for installation.
- After charging the refrigerant, check for leaks. Refer to [HA-23, "Leak Test"](#).

CONDENSER

< REMOVAL AND INSTALLATION >

CONDENSER

CONDENSER

CONDENSER : Exploded View

INFOID:000000012303621

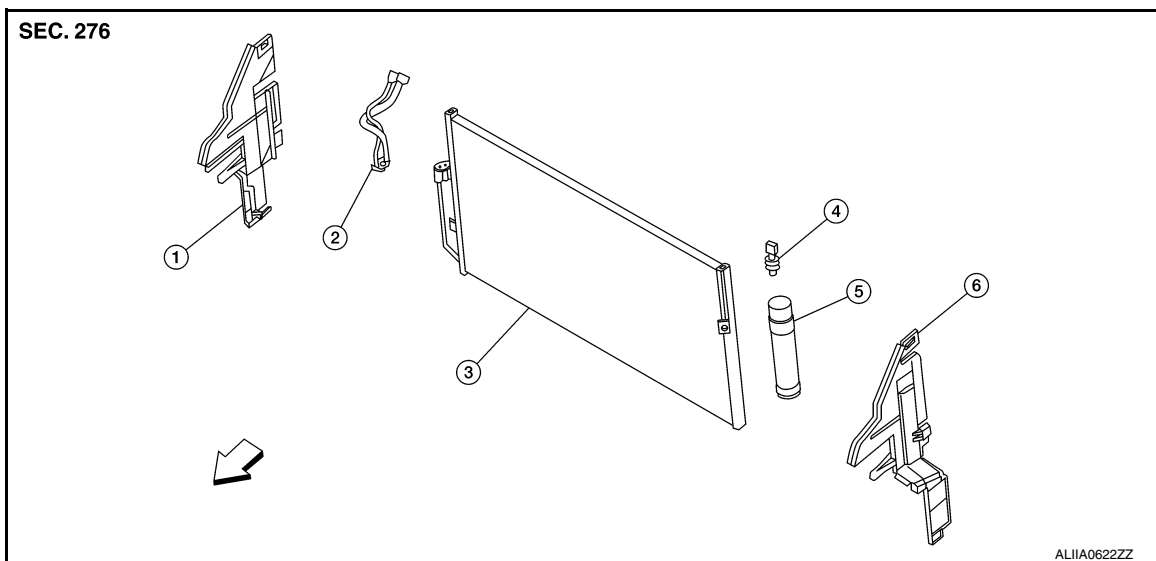

- | | | |
|---------------------------------|-------------------|---------------------------------|
| 1. Condenser air deflector (RH) | 2. Condenser pipe | 3. Condenser |
| 4. Refrigerant pressure sensor | 5. Liquid tank | 6. Condenser air deflector (LH) |

↩ Front

CONDENSER : Removal and Installation

INFOID:000000011933689

REMOVAL

1. Discharge the refrigerant. Refer to [HA-25, "Recycle Refrigerant"](#).
2. Remove the front bumper fascia. Refer to [EXT-17, "Removal and Installation"](#).
3. Remove the core support upper reinforcement.
4. Remove the RH side air guide.
5. Remove the retaining bolt and separate the condenser pipe from the condenser.
CAUTION:
Cap or wrap the joint of the pipe with suitable material such as vinyl tape to avoid the entry of air.
6. Disconnect the harness connector from the refrigerant pressure sensor.

CONDENSER

< REMOVAL AND INSTALLATION >

- Depress the top RH clip (A) and the top LH clip (B) to release the top condenser brackets as shown.
- CAUTION:**
 - **Do not damage the condenser fins**Slide the condenser and liquid tank assembly outward to release the condenser from the clips, then lower the condenser and liquid tank assembly from the vehicle.

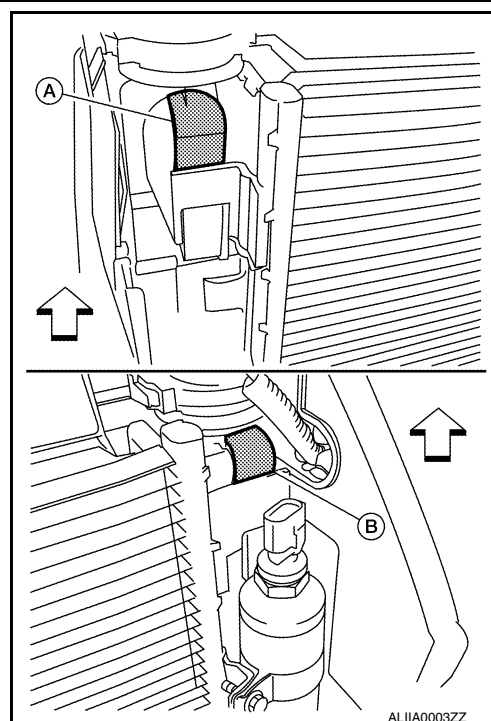

- Remove the liquid tank if necessary. Refer to [HA-42. "LIQUID TANK : Removal and Installation"](#).

INSTALLATION

Installation is in the reverse order of removal.

CAUTION:

- Do not damage the condenser fins.
- Do not reuse O-rings. Always install new O-rings.
- Apply A/C oil to the new O-rings during installation.
- After charging refrigerant, check for leaks. Refer to [HA-23. "Leak Test"](#).

CONDENSER PIPE ASSEMBLY

CONDENSER PIPE ASSEMBLY : Removal and Installation

INFOID:000000011933690

The condenser pipe assembly is serviced with the condenser and liquid tank assembly. Refer to [HA-41. "CONDENSER : Removal and Installation"](#).

LIQUID TANK

LIQUID TANK : Removal and Installation

INFOID:000000012372887

REMOVAL

CAUTION:

Cap or wrap the joint of the hose with a suitable material such as vinyl tape to avoid the entry of contaminants.

- Discharge the refrigerant. Refer to [HA-25. "Recycle Refrigerant"](#).
- Remove the core support cover.
- Disconnect the harness connector from the refrigerant pressure sensor.
- Remove the engine undercover. Refer to [EXT-26. "Removal and Installation"](#).
- Clean liquid tank and its surrounding area, and remove dirt and rust from liquid tank.

CAUTION:

Be sure to clean carefully.

CONDENSER

< REMOVAL AND INSTALLATION >

6. Remove bolt (A) and bolt (B) from the liquid tank (1) bottom and bracket.
7. Remove the liquid tank (1) with the bracket and refrigerant pressure sensor as an assembly. Slide the liquid tank (1) upward to release the bracket. Discard the two O-rings (2).

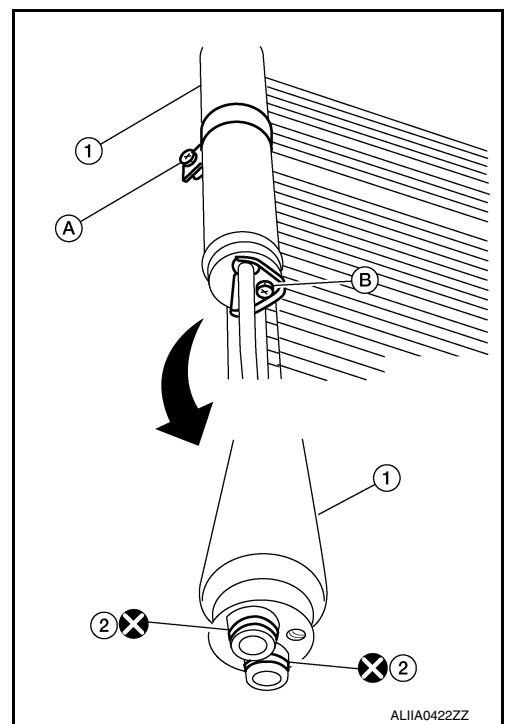

8. If necessary, remove the refrigerant pressure sensor from the liquid tank.

INSTALLATION

Installation is in the reverse order of removal.

CAUTION:

- Do not reuse O-rings.
- Apply A/C oil to the O-rings of the condenser for installation.
- After charging refrigerant, check for leaks. Refer to [HA-23, "Leak Test"](#).

REFRIGERANT PRESSURE SENSOR

REFRIGERANT PRESSURE SENSOR : Removal and Installation

INFOID:000000011933691

For removal and installation of the refrigerant pressure sensor, refer to [HAC-107, "Removal and Installation"](#).

HEATER & COOLING UNIT ASSEMBLY

< REMOVAL AND INSTALLATION >

HEATER & COOLING UNIT ASSEMBLY

Exploded View

INFOID:000000012308607

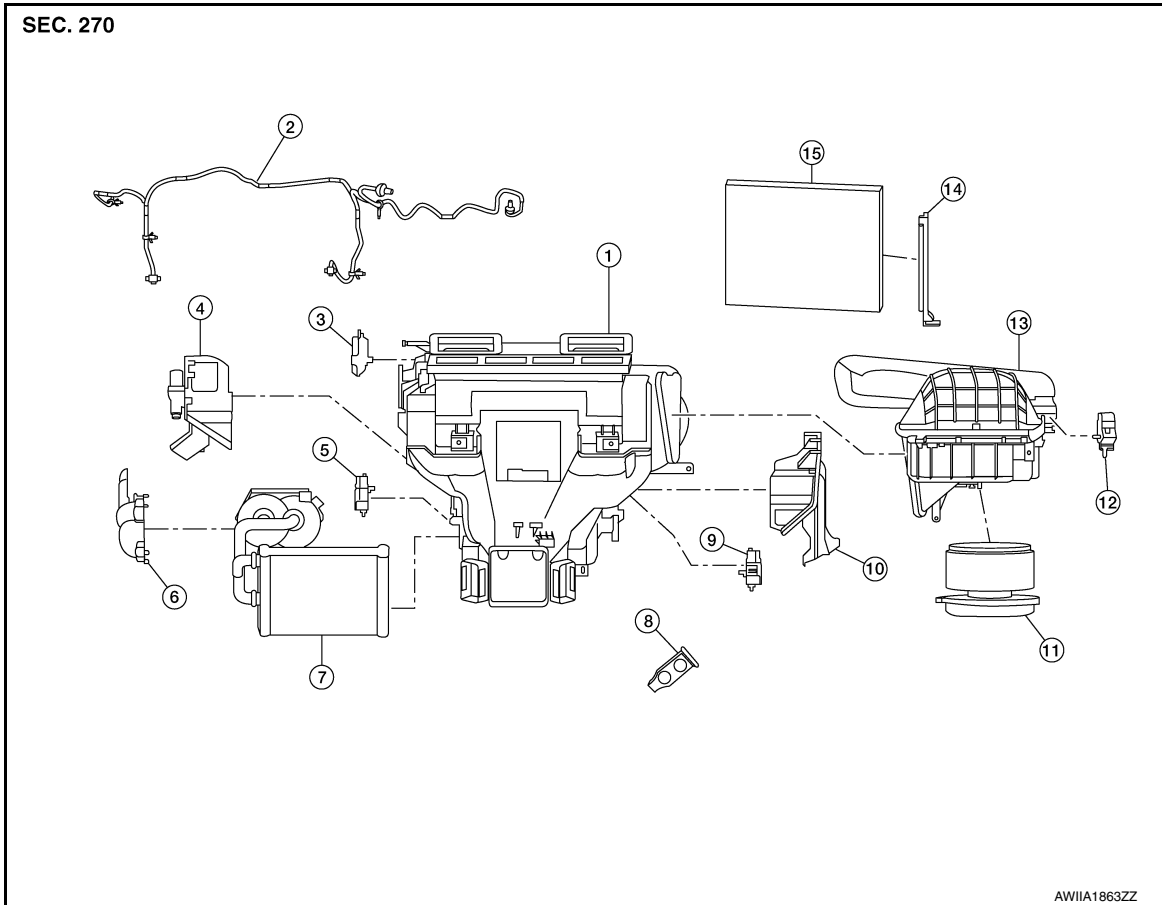

- | | | |
|--------------------------------------|--|-------------------------------------|
| 1. Heating and cooling unit assembly | 2. Wiring harness | 3. Mode door motor |
| 4. Upper floor connecting duct (LH) | 5. Air mix door motor (driver) (auto-
matic A/C only) | 6. Heater core pipes cover |
| 7. Heater core | 8. Air mix door motor (passenger) | 9. Upper floor connecting duct (RH) |
| 10. Expansion valve | 11. Blower motor | 12. Intake door motor |
| 13. Blower unit | 14. In-cabin microfilter cover | 15. In-cabin microfilter |

HEATER & COOLING UNIT ASSEMBLY

HEATER & COOLING UNIT ASSEMBLY

< REMOVAL AND INSTALLATION >

HEATER & COOLING UNIT ASSEMBLY : Removal and Installation

INFOID:000000012308608

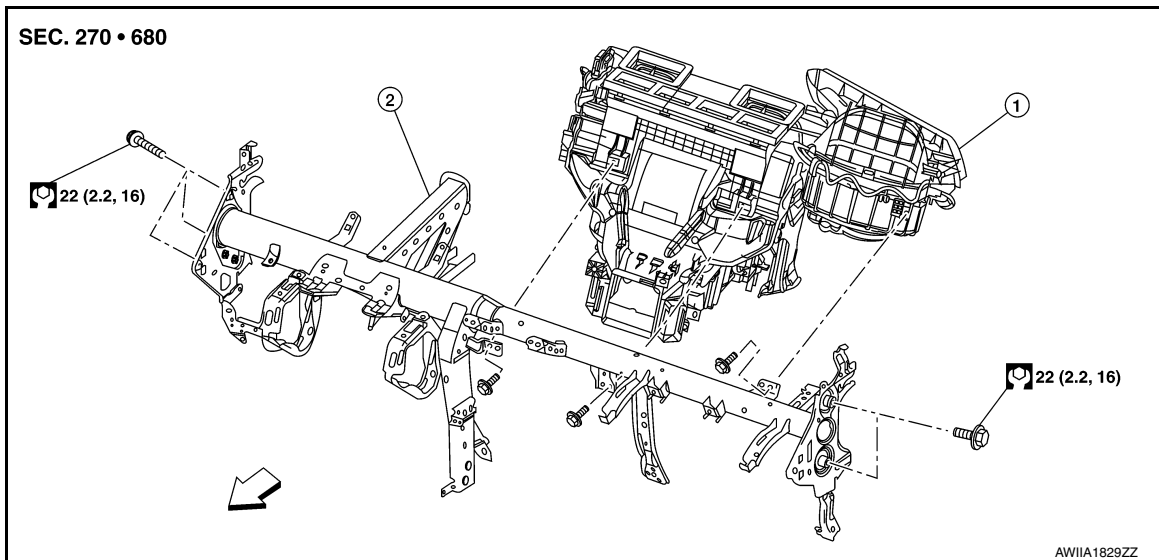

1. Heating and cooling unit assembly 2. Steering member ← Front

REMOVAL

1. Discharge the refrigerant. Refer to [HA-25, "Recycle Refrigerant"](#).
2. Drain the cooling system. Refer to [CO-12, "Changing Engine Coolant"](#).
3. Remove the instrument panel assembly. Refer to [IP-15, "Removal and Installation"](#).
4. Remove the steering column. Refer to [ST-32, "Removal and Installation"](#).
5. Remove the cowl top extension. Refer to [EXT-24, "Exploded View"](#).
6. Remove the LH lower cowl top extension.
7. Remove wiper motor. Refer to [WW-52, "Removal and Installation"](#).
8. Disconnect the low-pressure pipe from the expansion valve.
CAUTION:
Cap or wrap the joint of the pipe with suitable material such as vinyl tape to avoid the entry of air.
9. Disconnect the high-pressure pipe from the expansion valve.
10. Disconnect the heater hoses from the heater core pipes.
11. Remove instrument stay.
12. Remove front floor connecting duct (LH/RH). Refer to [VTL-8, "Exploded View"](#).
13. Remove the steering member covers bolts.
NOTE:
The steering member covers and bolts can be found near the cowl area in the door opening.
14. Remove the remaining steering member bolts.
15. Disconnect the fuse box harness and position the fuse box aside.
16. Disconnect the harness connectors from the heating and cooling unit assembly and steering member.
17. Remove the heating and cooling unit assembly and steering member as one assembly from the vehicle.
18. Separate the heating and cooling unit assembly from the steering member.

INSTALLATION

Installation is in the reverse order of removal.

CAUTION:

After charging refrigerant, check for leaks. Refer to [HA-23, "Leak Test"](#).

HEATER CORE

HEATER & COOLING UNIT ASSEMBLY

< REMOVAL AND INSTALLATION >

HEATER CORE : Removal and Installation

INFOID:000000012308609

REMOVAL

1. Remove the heating and cooling unit assembly. Refer to [HA-45, "HEATER & COOLING UNIT ASSEMBLY : Removal and Installation"](#).
2. Remove the heater core pipes cover. Refer to [HA-44, "Exploded View"](#).
3. Disconnect the harness connector from the blower motor.
4. Remove the heater core.

INSTALLATION

Installation is in the reverse order of removal.

EVAPORATOR

EVAPORATOR : Removal and Installation

INFOID:000000012308610

REMOVAL

1. Remove the heater core. Refer to [HA-46, "HEATER CORE : Removal and Installation"](#).
2. Remove the upper floor connecting duct (RH). Refer to [VTL-8, "Exploded View"](#).
3. Remove the air mix door motor (driver). Refer to [HAC-110, "AIR MIX DOOR MOTOR : Removal and Installation - Air Mix Door Motor \(RH\)"](#).
4. Remove the air mix door motor (passenger) (if equipped). Refer to [HAC-109, "AIR MIX DOOR MOTOR : Removal and Installation - Air Mix Door Motor \(LH\)"](#).
5. Disconnect the harness connector from the intake sensor.
6. Remove the evaporator and expansion valve assembly.

INSTALLATION

Installation is in the reverse order of removal.

NOTE:

The evaporator can only be ordered as an assembly with the expansion valve.

EXPANSION VALVE

EXPANSION VALVE : Removal and Installation for Expansion Valve

INFOID:000000012308611

REMOVAL

1. Discharge the refrigerant. Refer to [HA-25, "Recycle Refrigerant"](#).
2. Remove the strut tower brace. Refer to [FSU-18, "Exploded View"](#).
3. Disconnect the low-pressure pipe from the expansion valve.
4. Disconnect the high-pressure pipe from the expansion valve.
5. Remove the expansion valve bolts.
6. Remove the expansion valve.

INSTALLATION

Installation is in the reverse order of removal.

CAUTION:

After charging refrigerant, check for leaks. Refer to [HA-23, "Leak Test"](#).

SERVICE DATA AND SPECIFICATIONS (SDS)

< SERVICE DATA AND SPECIFICATIONS (SDS)

SERVICE DATA AND SPECIFICATIONS (SDS)

SERVICE DATA AND SPECIFICATIONS (SDS)

Compressor

INFOID:0000000011933697

Make	DENSO
Model	6SBH14C
Type	Variable displacement swash plate
Displacement	140.6 cm ³ (8.58 in ³) / revolution
Cylinder bore × stroke	32.0 mm (1.26 in) x 29.1 mm (1.15 in)
Direction of rotation	Clockwise (viewed from clutch)
Drive belt	Poly V 7-grooves

Oil

INFOID:0000000011933698

Name	ND-OIL8 (DENSO)	
Capacity	Total in system	100 mℓ (3.4 US fl oz, 3.5 Imp fl oz)
	Compressor (service part) charging amount	Refer to HA-28, "Oil Adjusting Procedure for Compressor Replacement" .

Refrigerant

INFOID:0000000011933699

Type	HFC-134a (R-134a)
Capacity	0.55 ± 0.025 kg (1.21 ± 0.055 lb)